



FIREPLACE & KITCHEN HOOD CATALOG

Dear friends,

We at Renaissance Cast Stone, are proud to offer our Fireplace book.
We are constantly updating or creating new mantels so keep up with our
newly renovated website for current updates to this book

www.renaissancecaststone.com

As always, Renaissance prides itself on our ability to produce the finest
dry tamp cast stone in the region, along with the most comprehensive
customer care, before and after the sale.

We encourage you to take a look at some of our work available @

Bachels By The Fire

9244 N May Ave. Oklahoma City, OK 405-842-8872

Monticristo Ironworks

5609 NW 4th St, Oklahoma City, OK 73127

(405) 787-0111

As the owner and master mold crafter, I want to thank you for you kind
words and continued business with us.

I look forward to building your next fireplace!

Kind regards,

Genaro Arriaga

GM /Master Craftsman

Renaissance Cast Stone

2135 SW 19 th Street,

Oklahoma City, OK 73108

Tel:(405) 514-4780

Fax:(405) 563-9065

About this book:

As with any cast stone company who posts pricing in a catalog, there are some additional costs associated with the price in the book. We will try to prepare you for your budgets as close as we can but keep in mind that some things like freight will always be unpredictable until time of shipment.

About Tracy

Tracy is the figure you see standing next to all the fireplace drawings. She is 5'-7" tall with heels. She is there as a benchmark in terms of scale. To give you an idea as to just how large or small things can be in relation to you and your project.

5'-7"

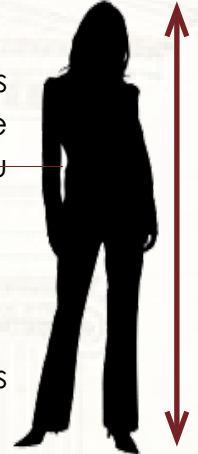

About Additional Costs

Handling is a packaging charge associated with placing the stone on pallets and protecting them in plastic for shipment.

Installation

Is assessed per job and can vary based on job site location and conditions present at time in installation. You can either request installation be done by Renaissance (on fireplaces and Kitchen hoods only), or the mason who is installing your brick / rock package.

Shipping

-As stated above will be estimated at the time of the bid and actualized when the product ships.

Taxes

Local taxes will be assessed to the ship to address and applied at final

Billing.

Deposits of 1/2 of the total estimate will be required to begin the process of creating shop drawings and starting the manufacturing process.

Finish And Color Options

There is no xtra charge for our smooth finish and six natural colors of white, buff, dark buff, limestone, sahara and natural grey. Antique finish requires an additional 25% of materials cost up charge. Additional color charges are individually based.

Sealing

We recommends sealing your fireplace and have two different sealer options. Please ask your representative for information about sealing and the option of doing it yourself!

A C A N T U S





The Acantus

A beautiful ornate leaf leg with exceptional mantel accents, the Acantus can't help but impress.

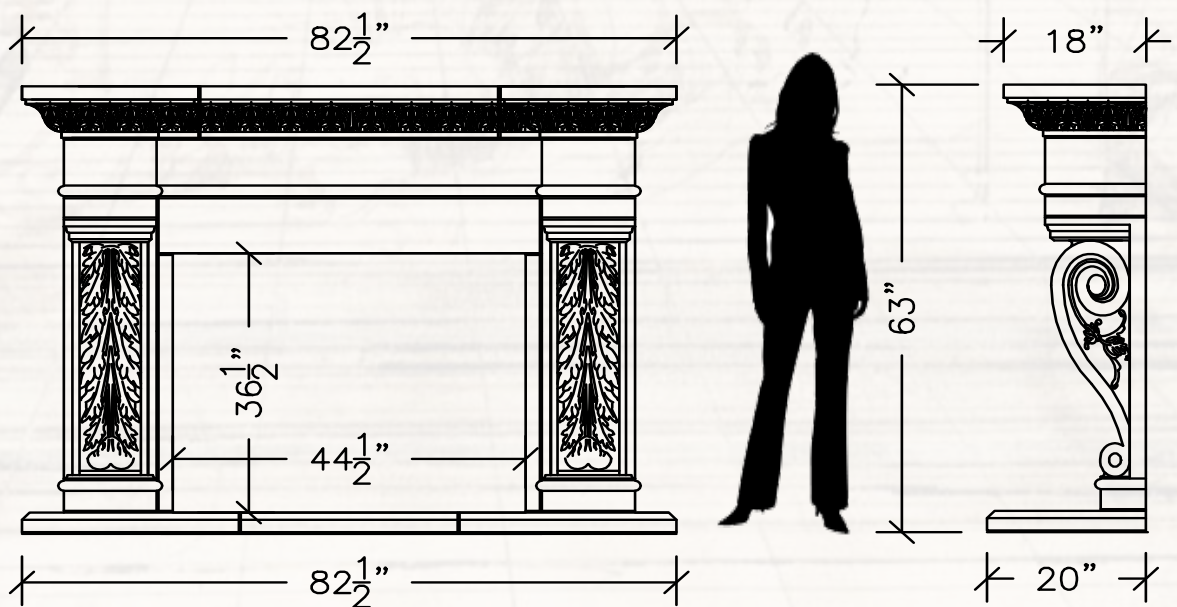

AGRA





The Agra

The Agra combines ornate leaves with stately columns in fine fashion. Accent medallions finish this classic design.

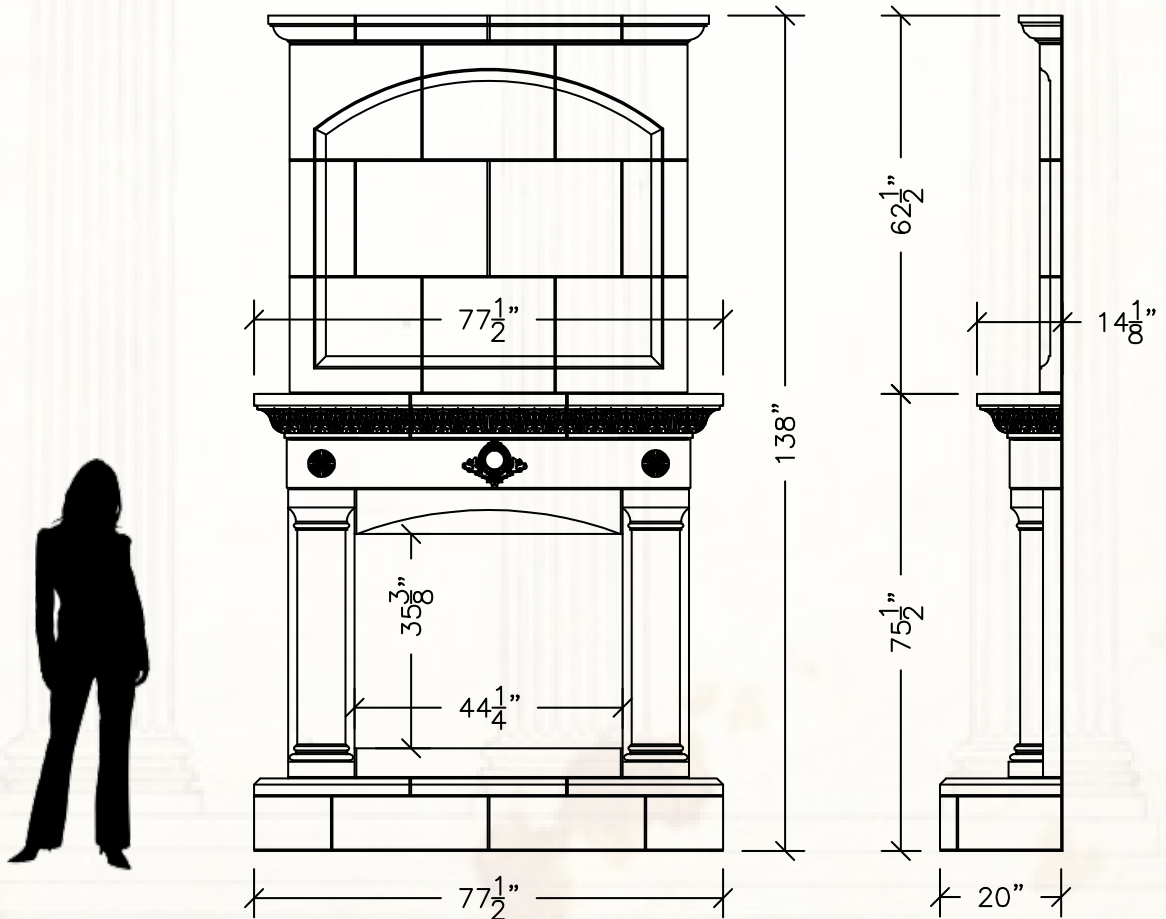

ALIBI





The Alibi

No Excuses here. A great combination of top heavy mantels on ornate corbels perched on flat leg bases. A lovely piece for a small room, or a study.

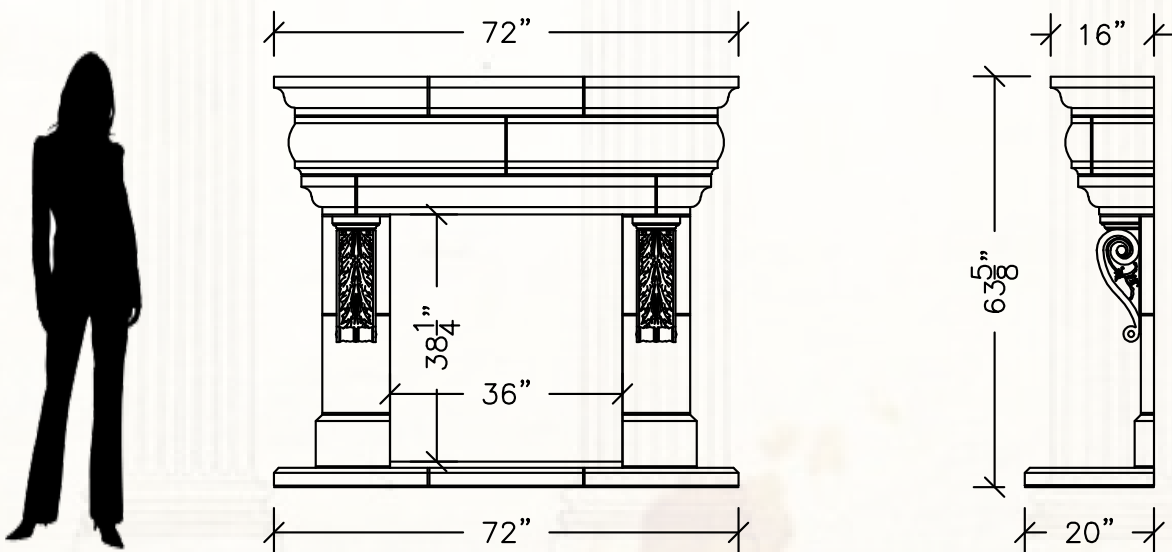

A L O R A





The Alora

The first design in a series of five affordable yet beautiful cast stone fireplace mantels.

The "Builder Series" offers elegantly simplistic lines and clean designs that range from contemporary to traditional. Keep an eye out for the next four.

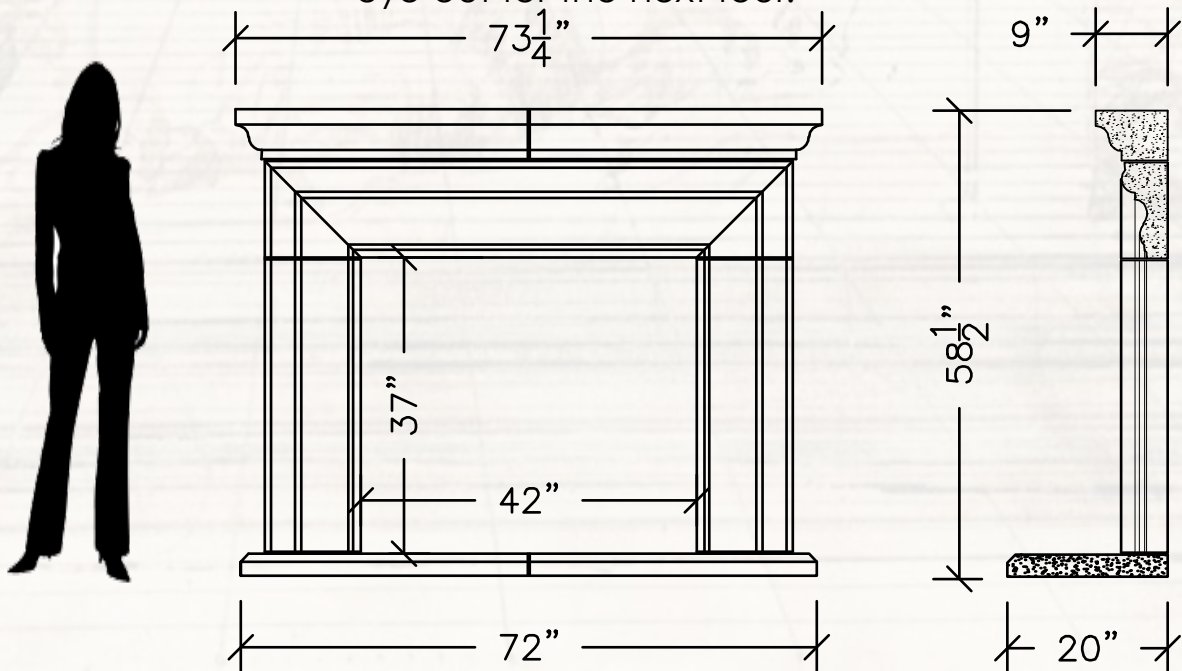

ARCO





The Arco

With clean lines and arches, this strong mantel, wide leg and foot lends to a deceptively massive appearance yet does not crowd the room.

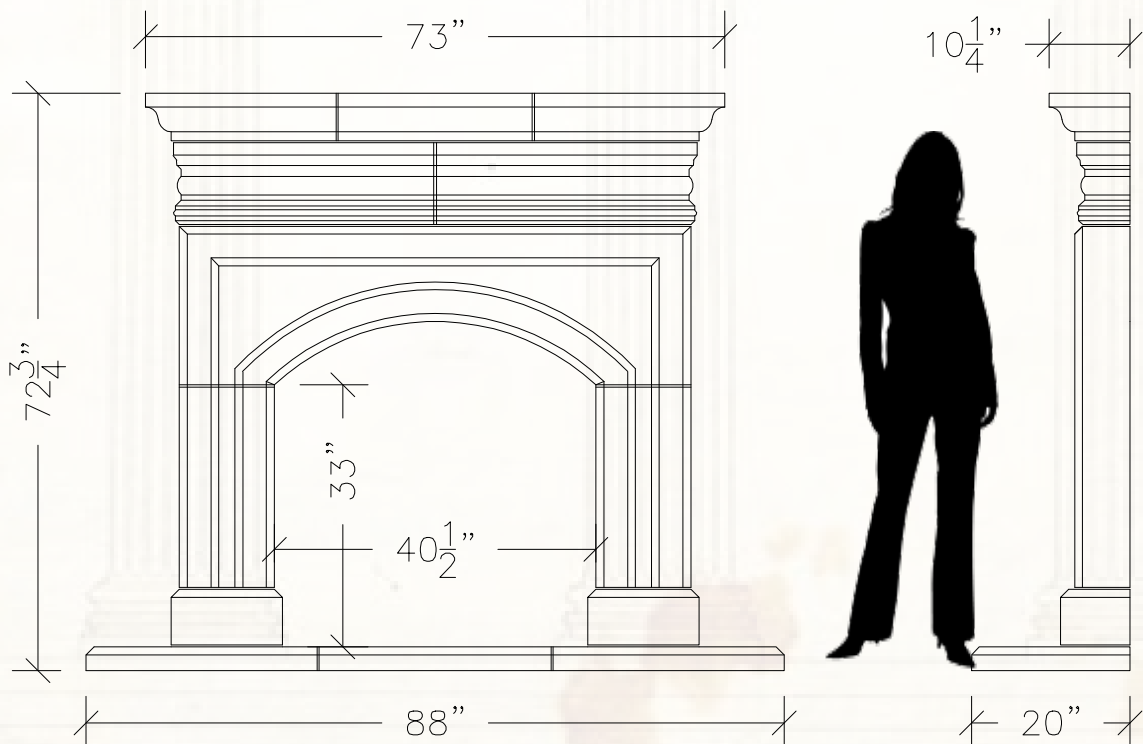

ARCO DE HERRADURA





Arco De Herradura

The "Horseshoe Arch" of Arabic decent gives the spice of the ancient culture's sophistication, married with the archetypal columns of ancient Rome and Greece. "Doves of Peace" soar the corners.

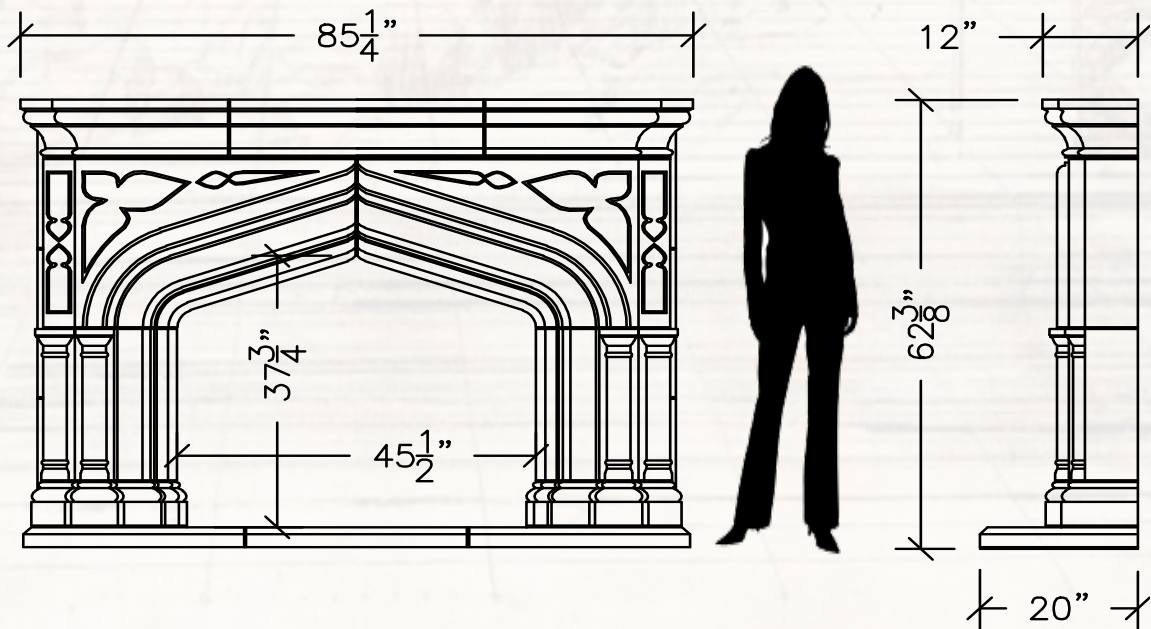

ATLAS



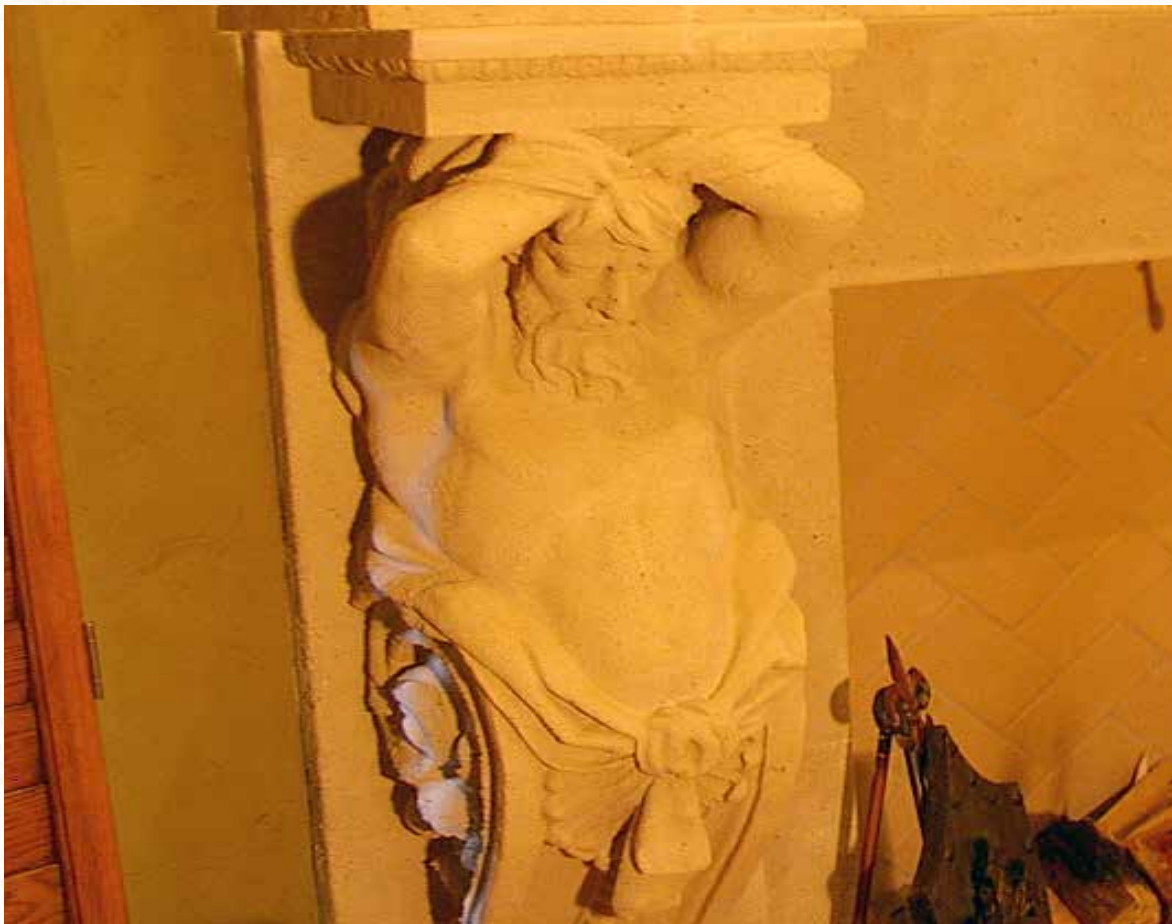

The Atlas

An easier job for Atlas to hold up this mantel than the universe.
This beautiful adaptation captivates the imagination while holding up it's homage to Greek architecture.

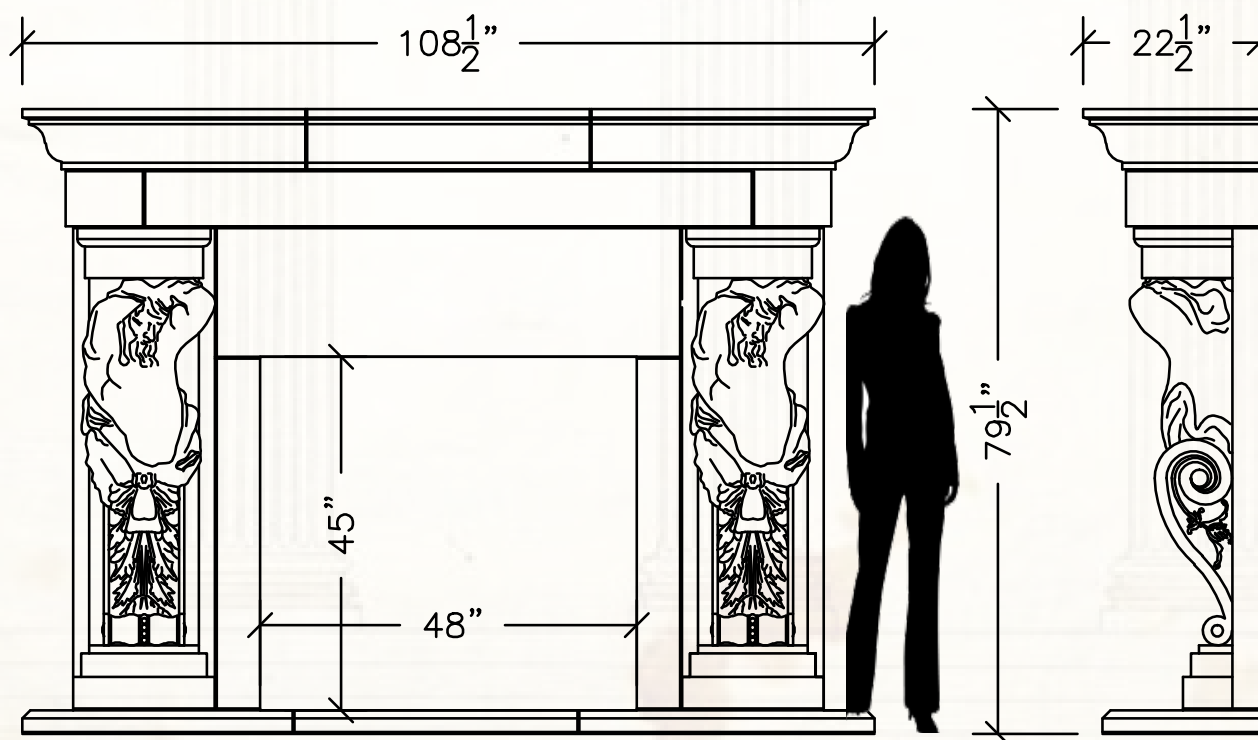

BELLA GAMBÀ





The Bella Gamba

“Beautiful legs” and fine attention to detail, this robust design makes perfect sense in each and every detail along it’s sturdy double mantels to it’s corbeled leg tops.

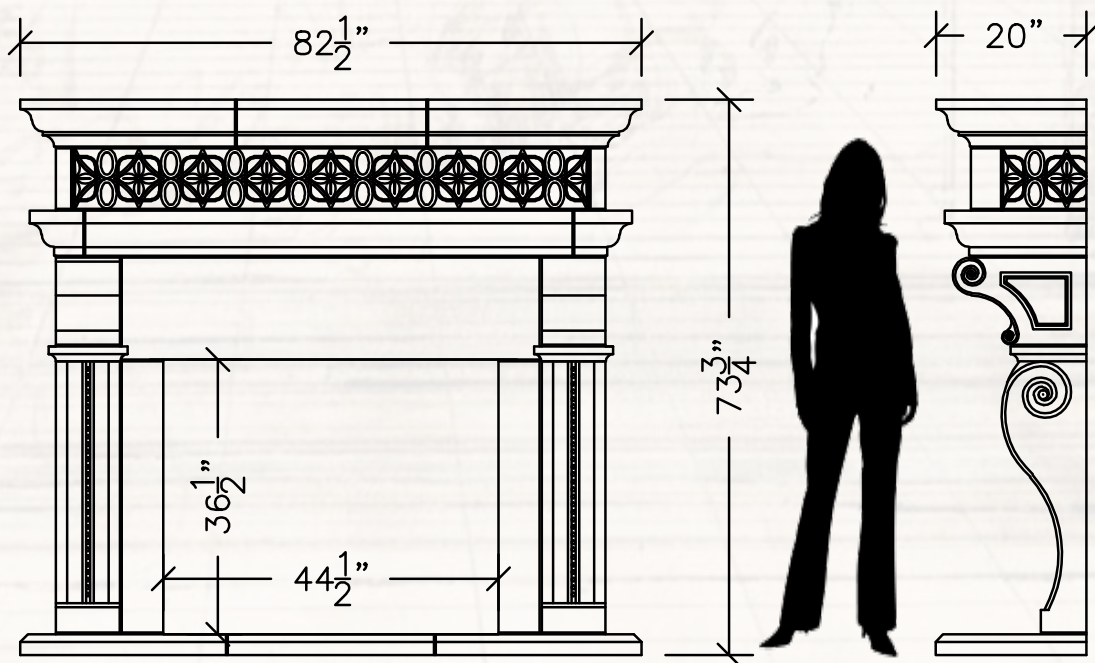

BELLA LEE





The Bella Lee

With columns for legs and a block style radius mantel, this offering carries a southern style charm into your room.

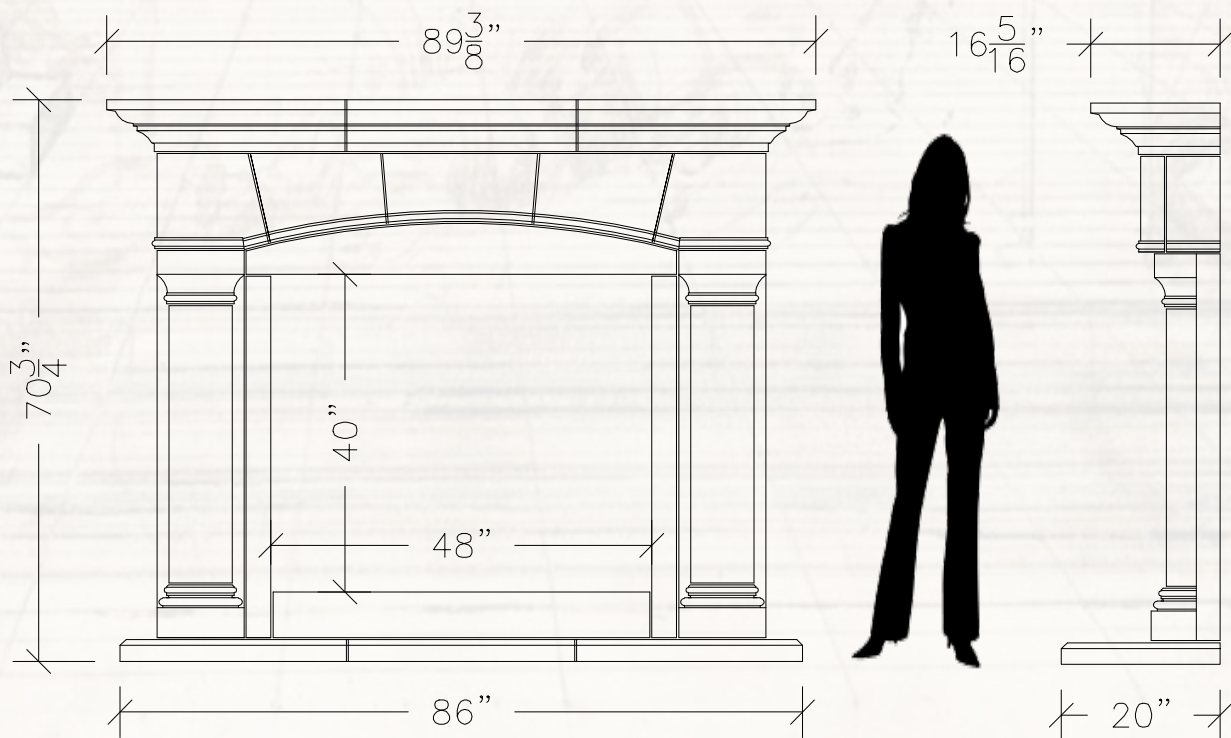

BRISBANE





The Brisbane

The details and overall size of this marvelous mantel make it a standout in the Renaissance Cast Stone line. Each time you study what seems to be a fairly ordinary design, your eyes discover another subtle complexity.

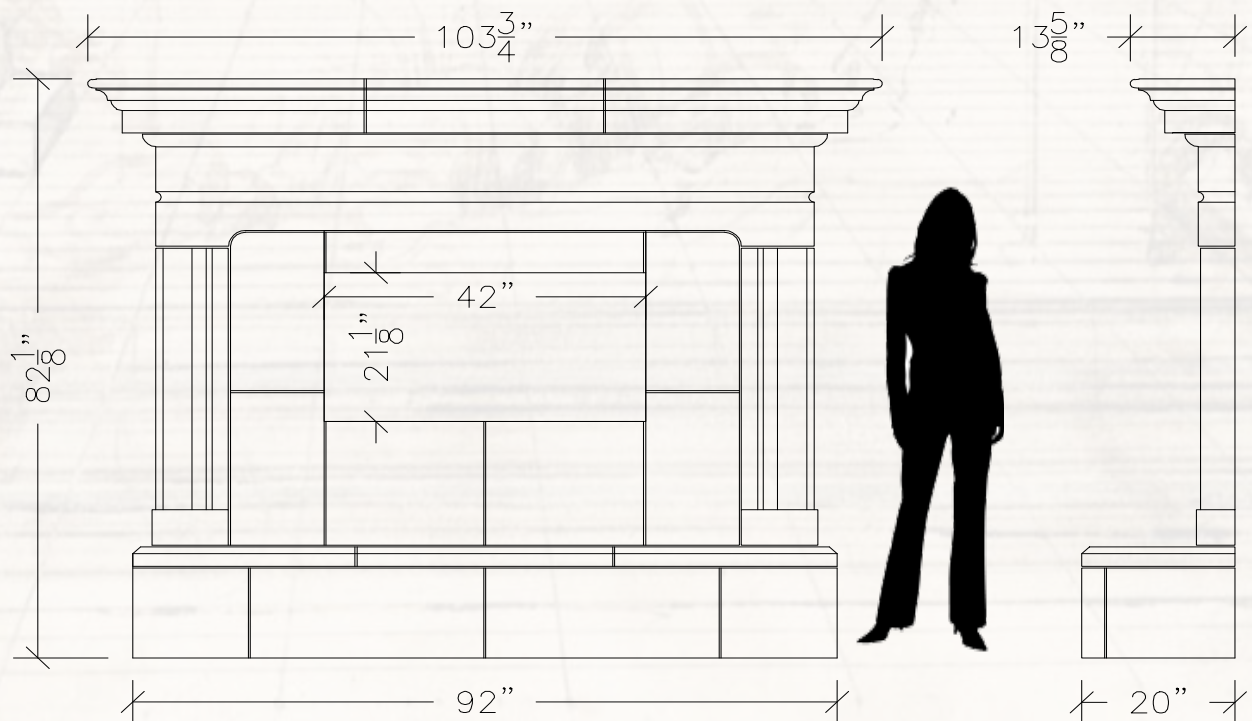

CASCADE





The Cascade

Unique fire box design, and thick bold legs support the gently curved upper mantel blocks.

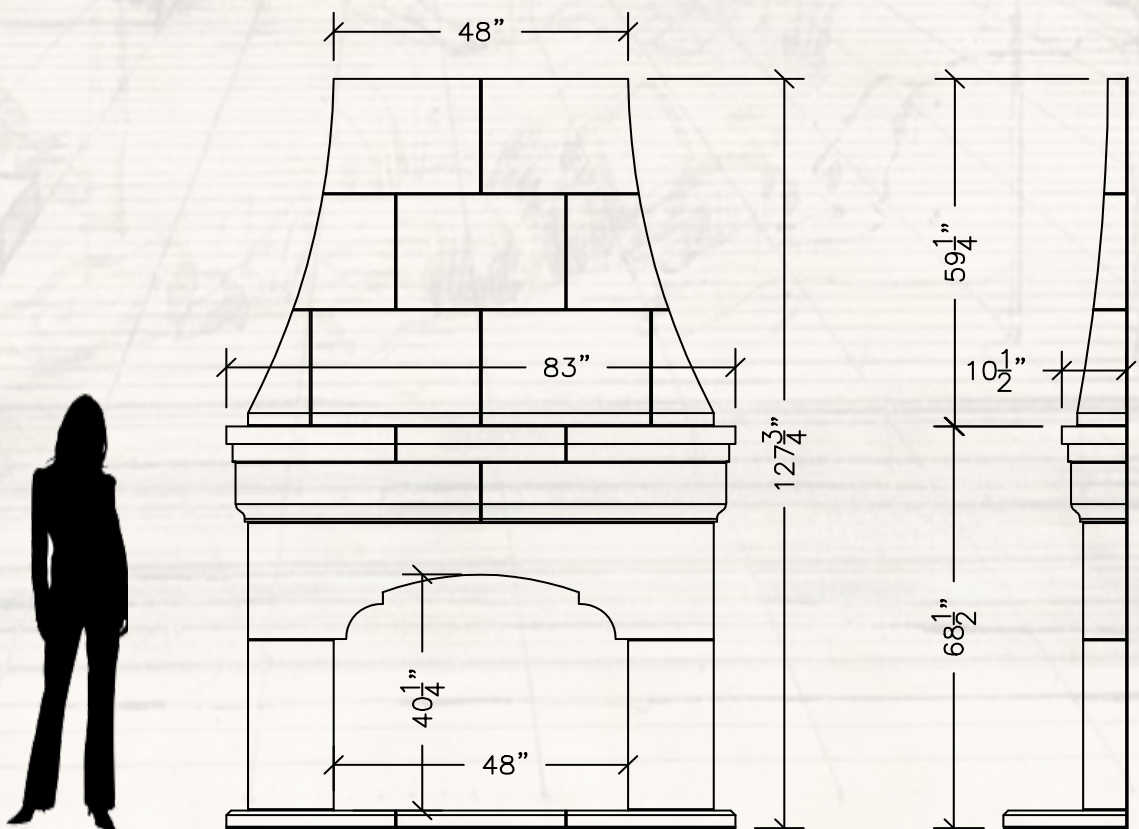

CORVARE



ANTIQUE FINISH

The Corvare
Marries simplistic lines with complex curves. An impressive girth on the mantel allows for plenty of space for decoration! Shown above with our new "Antique" finish.
Available in a 36" or 42" firebox designs.

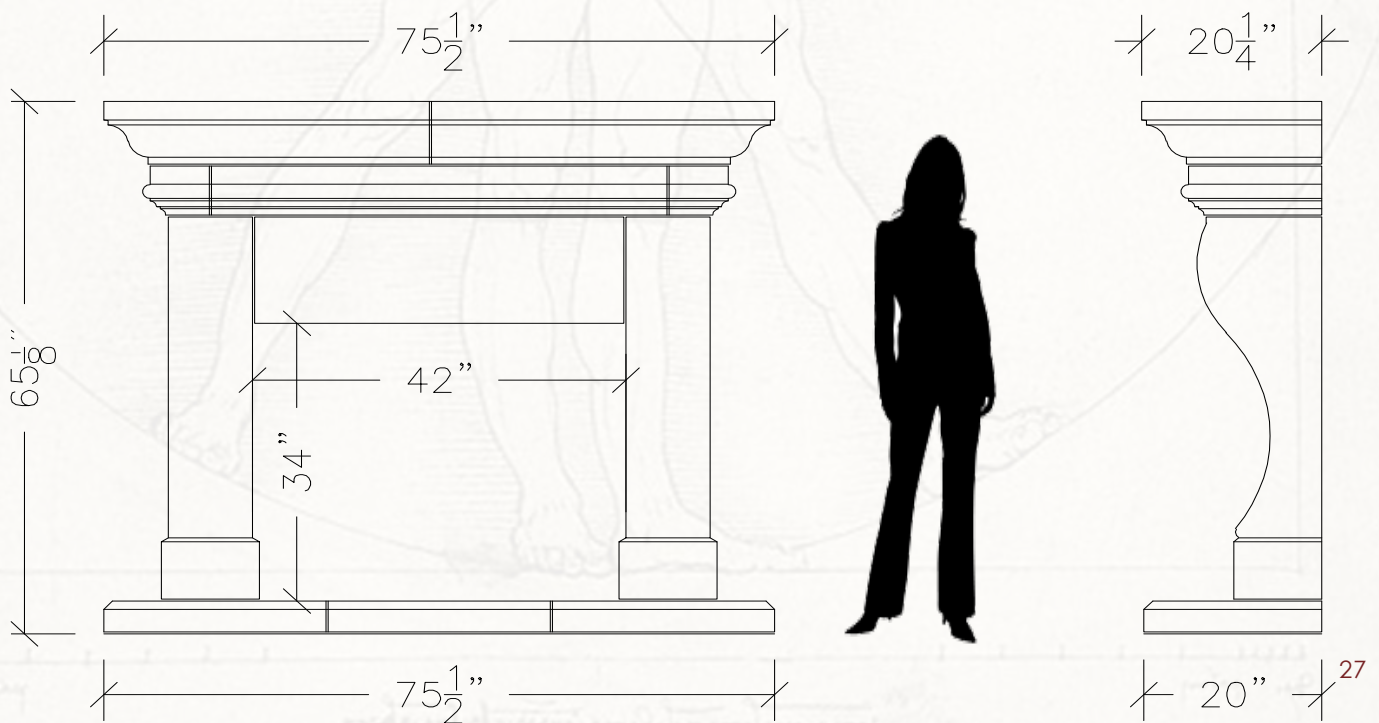

DIJON





Dijon

This orderly mantel and upper looks divine in your space. French country inspiration runs throughout.

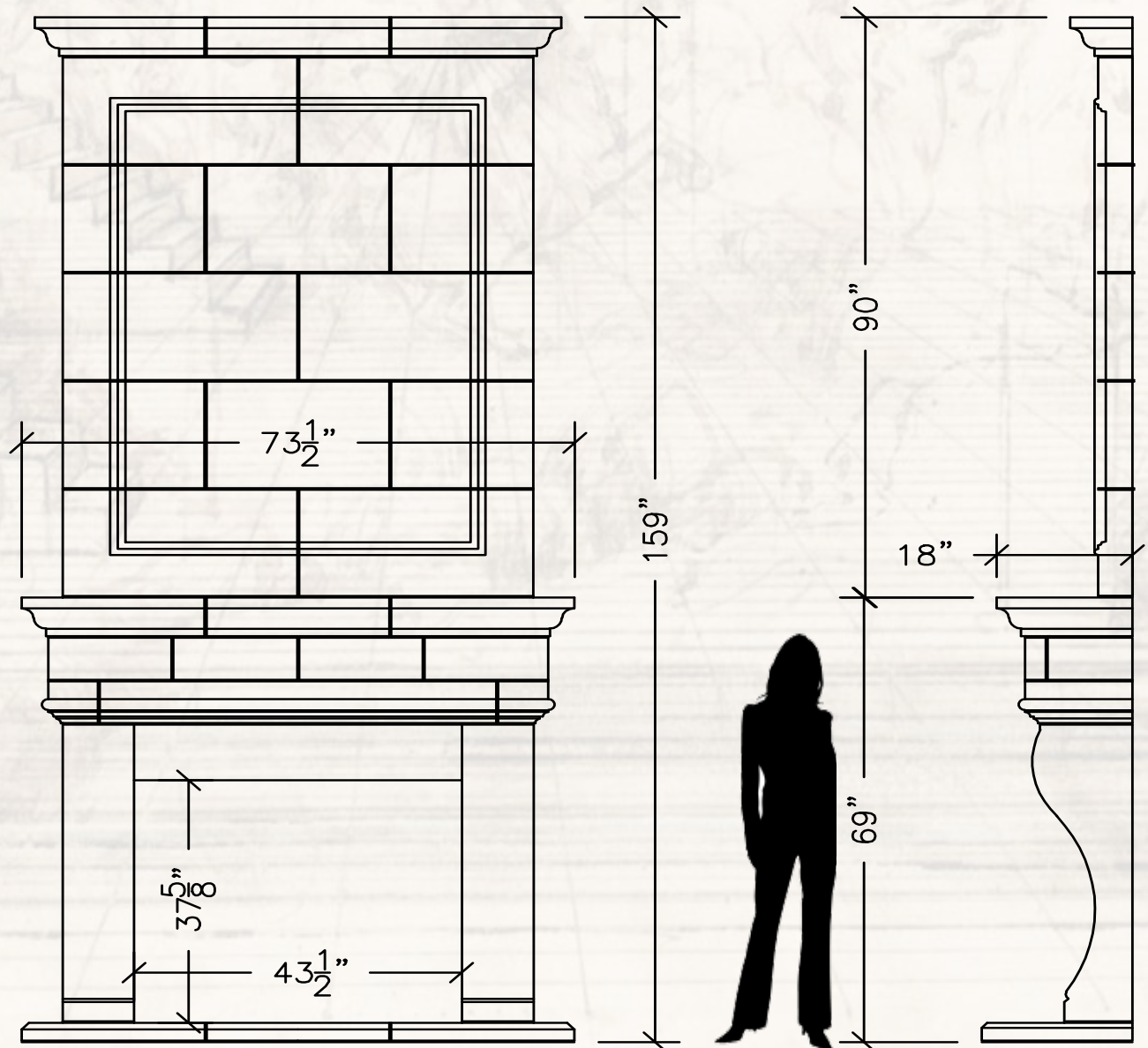

ELEGANTE





The Elegante

Featuring double mantels and eyebrow panels with neatly defined trim on the legs. Truly elegant.

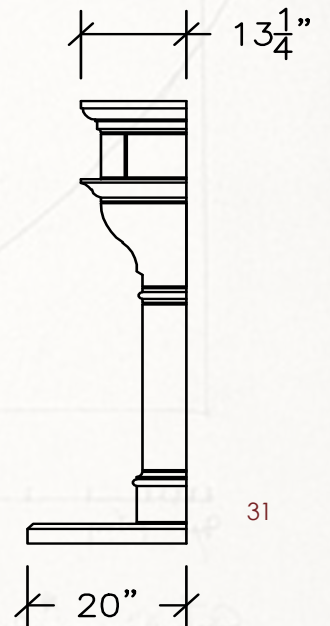
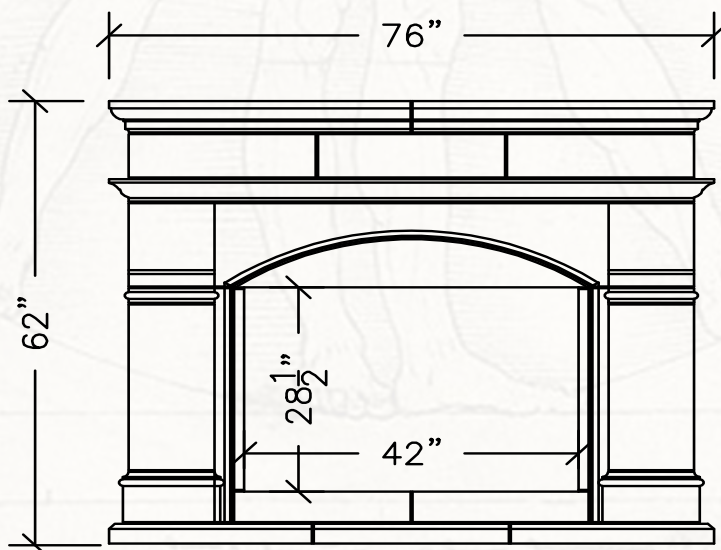

FIRENZE





Firenze

“ Florence” the ornate legs inspired by the Florence Cathedral cool the room instantly with a historic yet subtle feel.

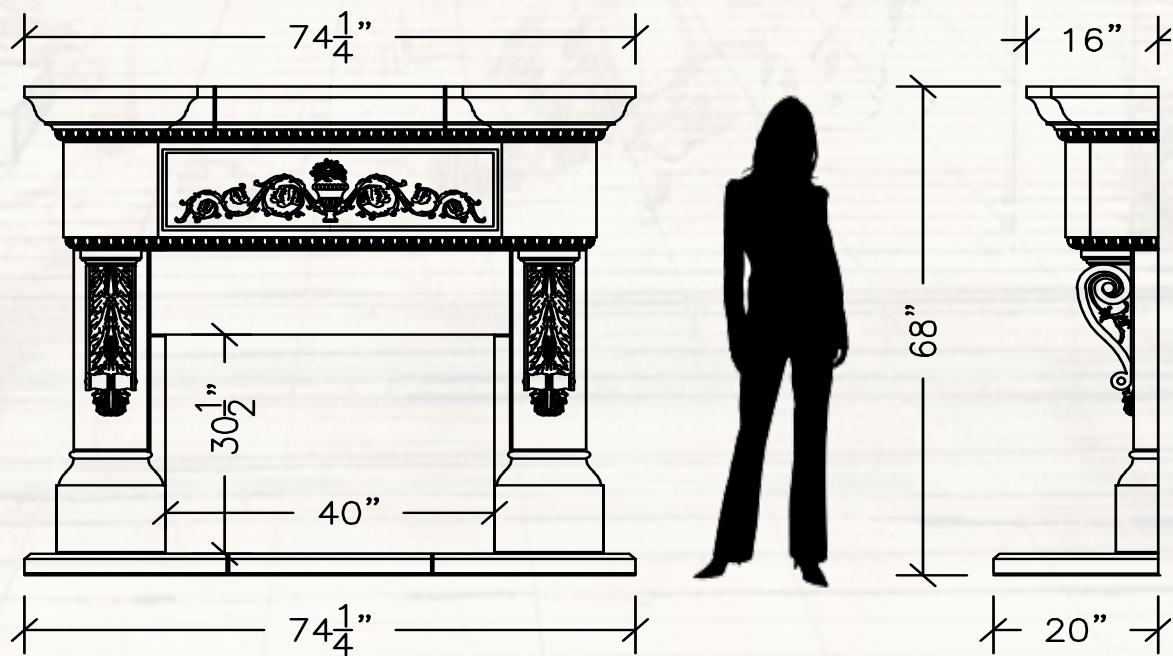

FLATUO TORO





Flauto Toro

The name refers to the fluted legs under the bullnose shapes on this clean design.
A quiet punctuating statement indeed.

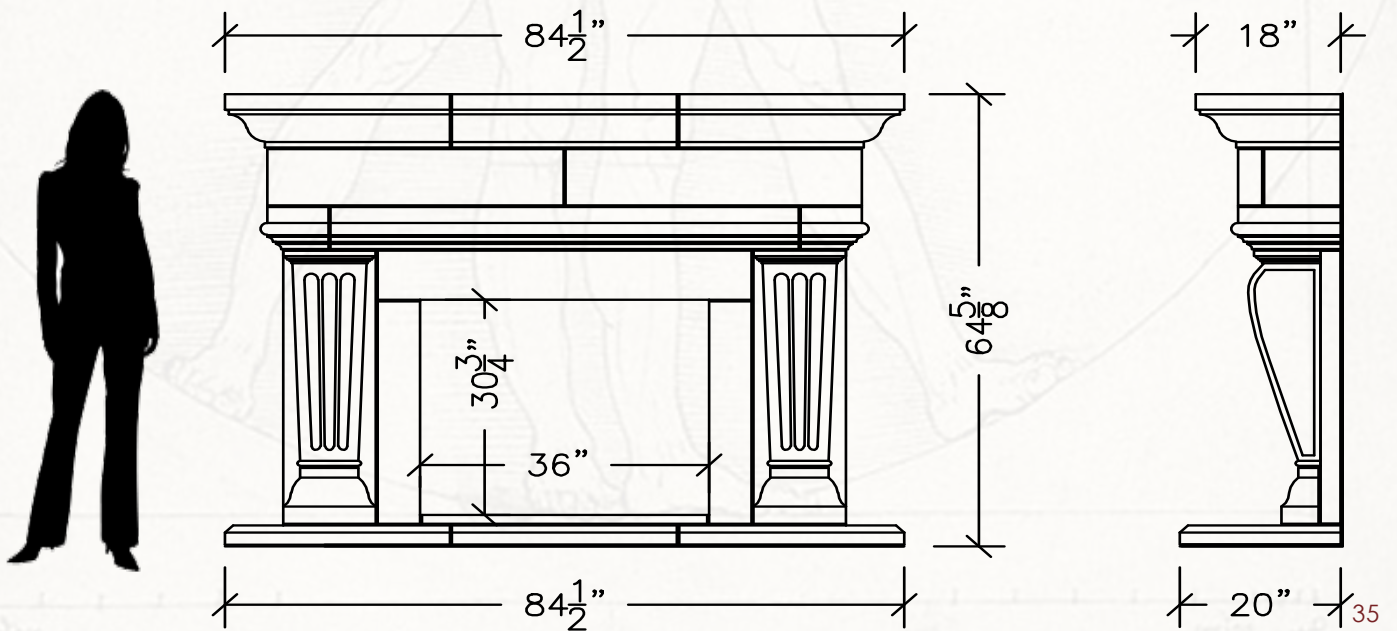

FORCHETTA





The Forchetta

Italian for fork, the leg designs look like dinner fork splines embedded in a slight arch much like the real thing. The statement is clear, strong and peaceful in presence. (Shown with taper upper mantel)

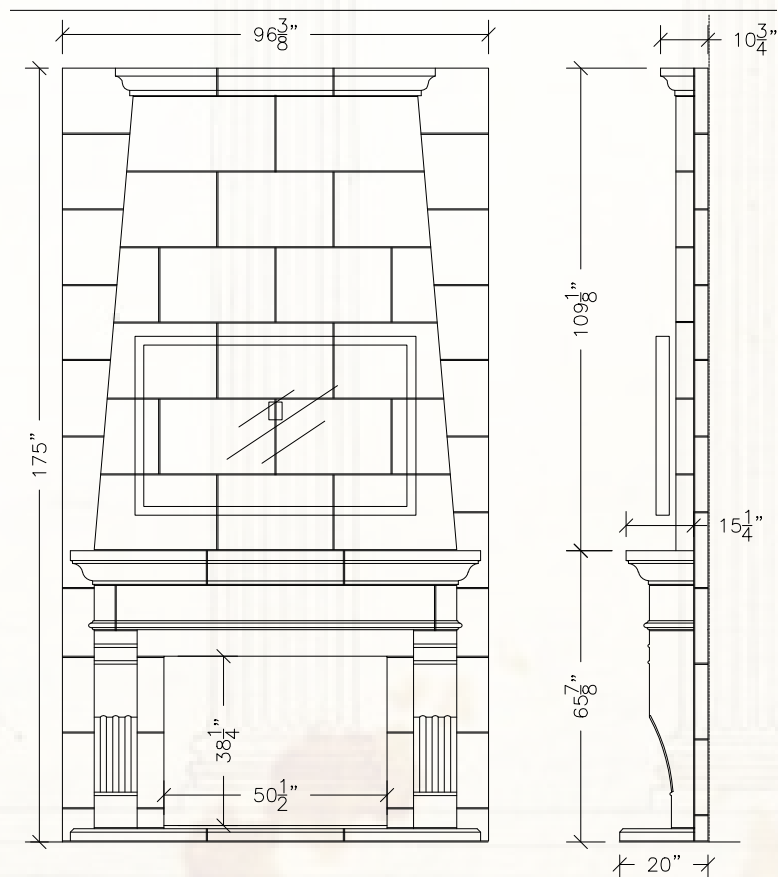

GRABEL





The Grabel

The Grabel, second in our Ode to Italy series is shown acid stained. Yet another in a series of simplistic, yet strong statements. Classic lines are hard to argue, as the presence of this piece will not be overlooked.

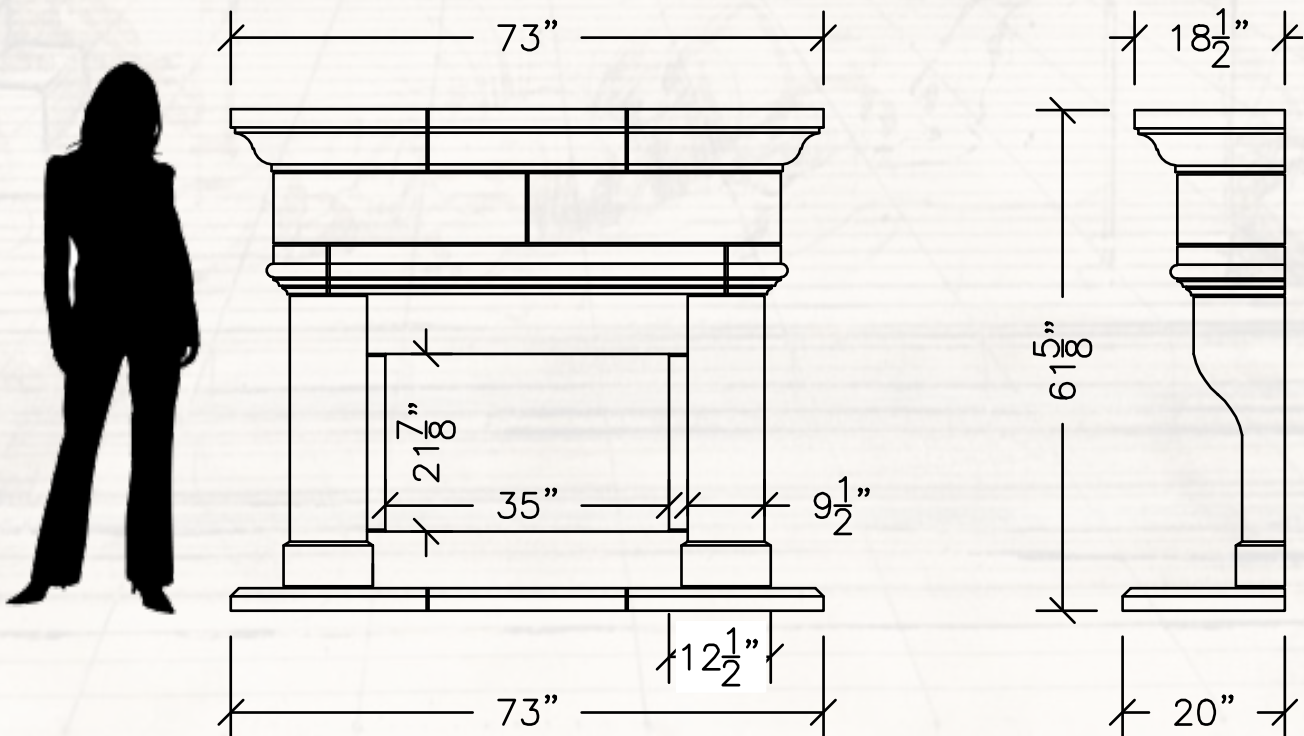

GRECCO ROMAN





The Grecco Roman

"Pretty Ears" A regal sight to behold. This mantel seems to be listening in to the chorus of applause and awe from your guests.

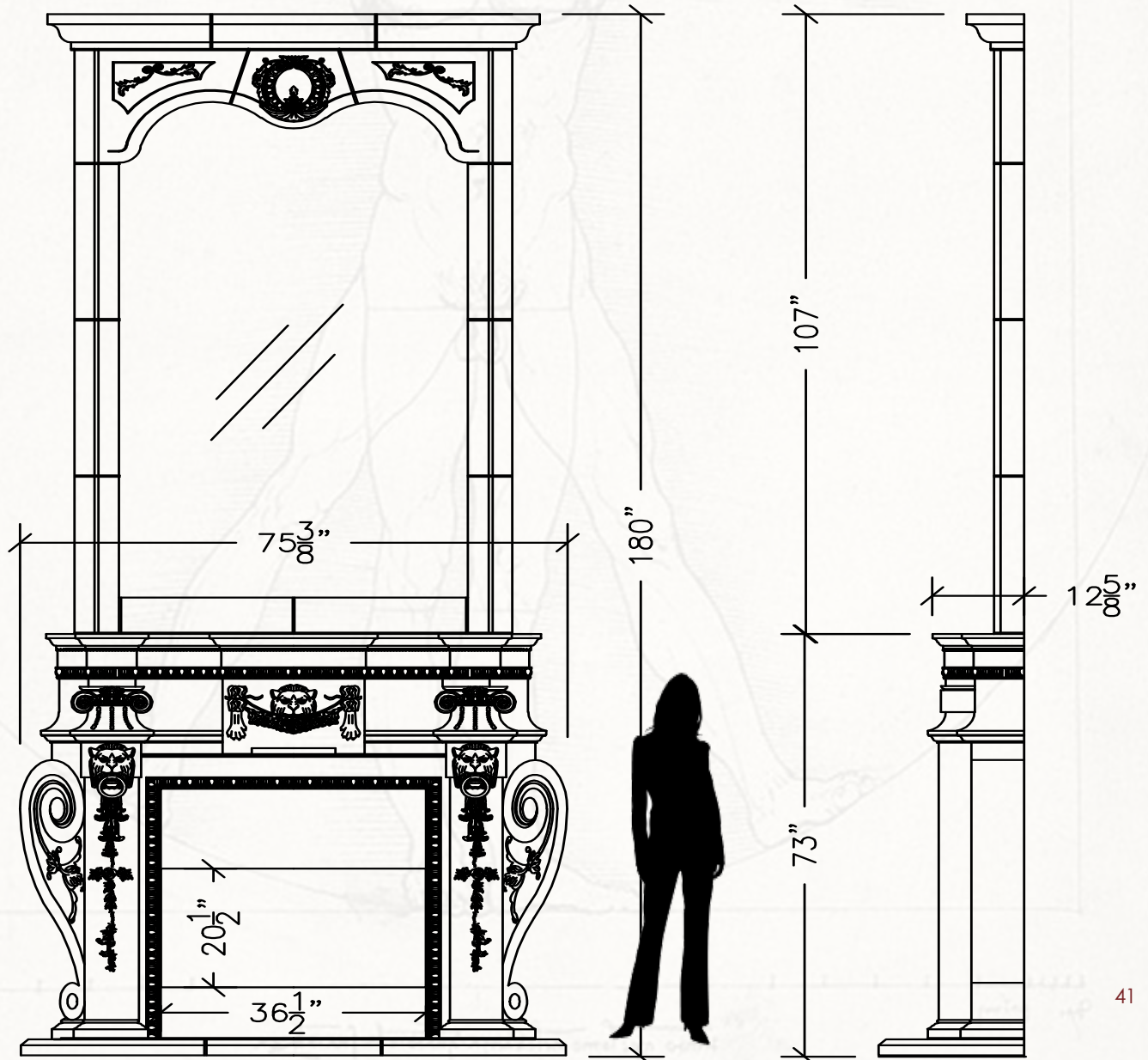

GROTTA





ROCK SALT FINISH

The Grotta

This design has a cave like effect, jutting out from the firebox some 8" or more. Shown here with an upper mantel and a rock salt finish, this fireplace is fashionably diverse as it can set a mood in a contemporary, Cape or French Country atmosphere. Available in a 36" or 42" firebox designs

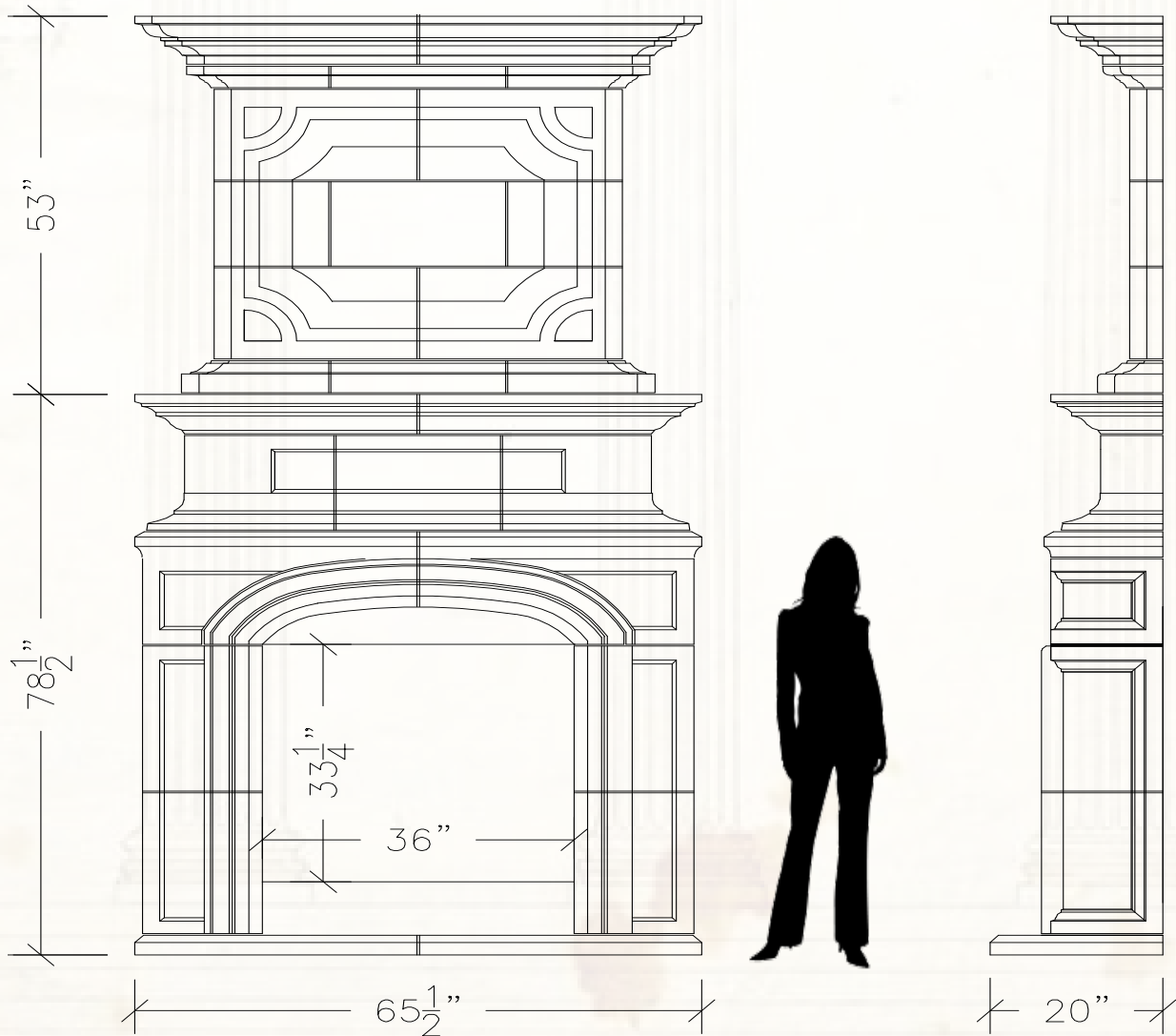

HECTOR





Hector

Like the warrior of Greek and Roman myth, let this Hector be the Prince of your royal house

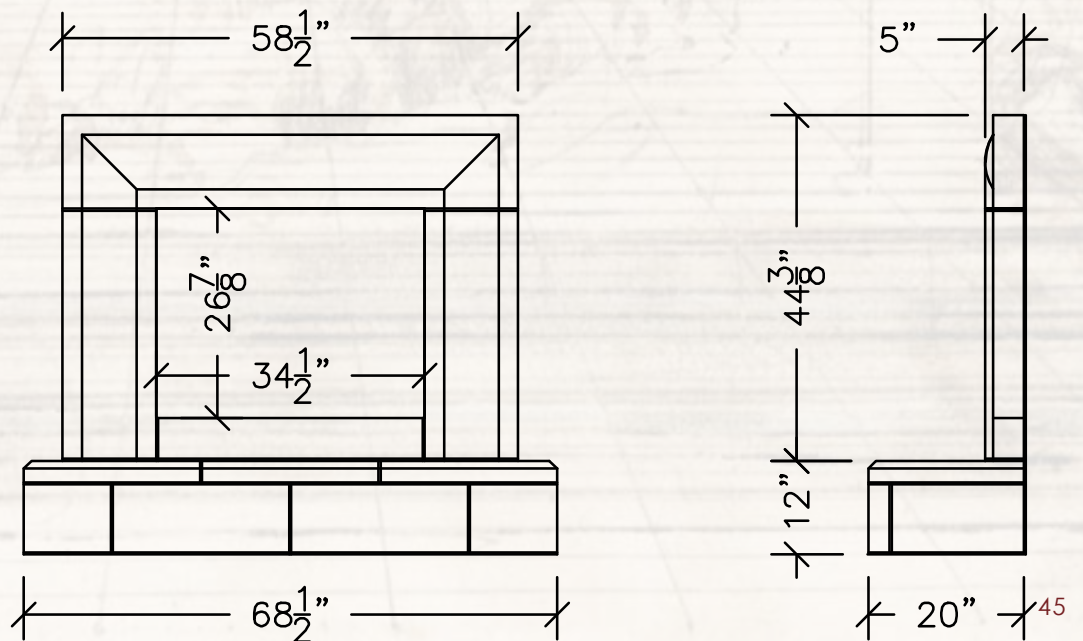

IGNATIUS





Ignatius

This was the name of several saints, some of which enjoyed lavish lifestyles which this design reflects.

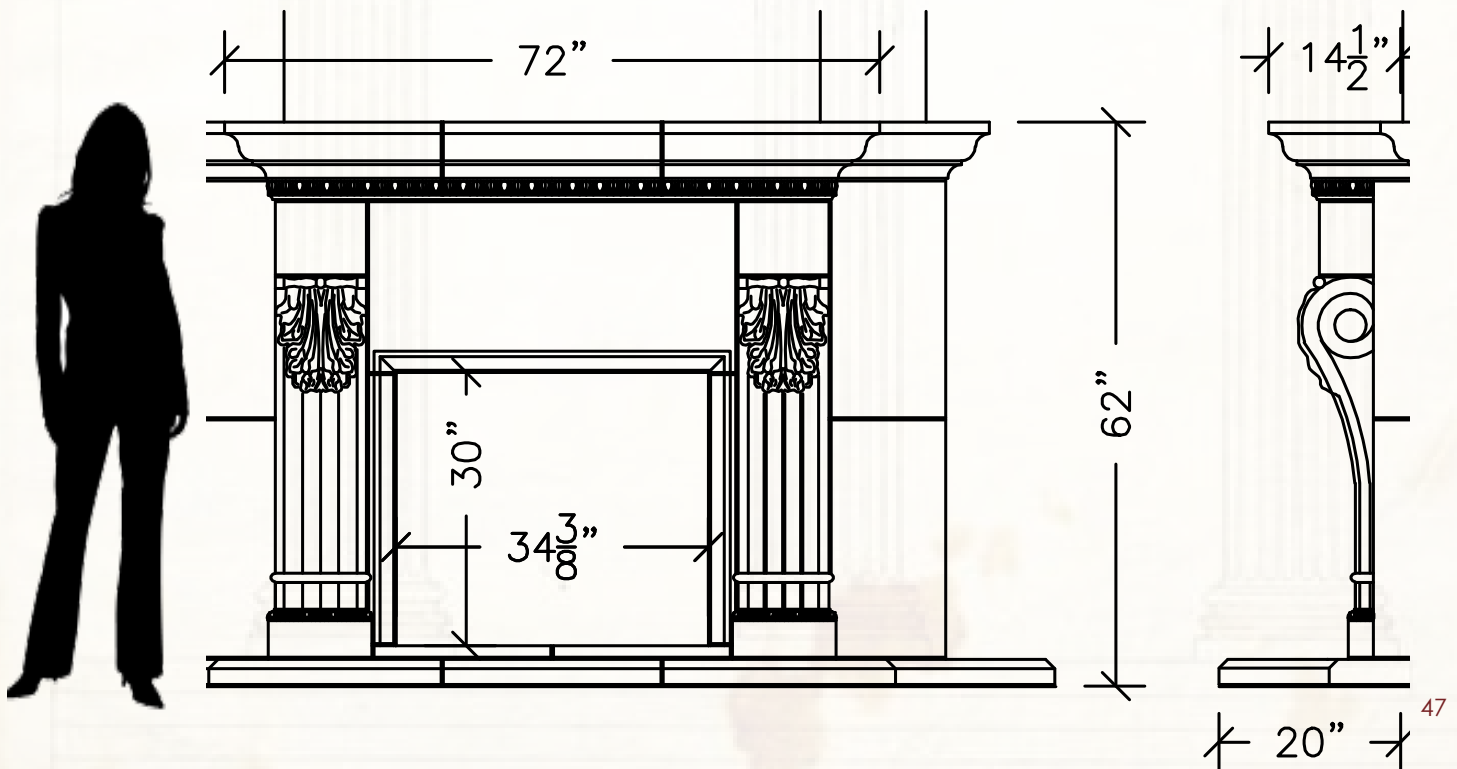

LEONE D RAFFINATO





Lione d' Raffinato

Our "refined Lion" is named after its lion-like paws at the base of the legs.

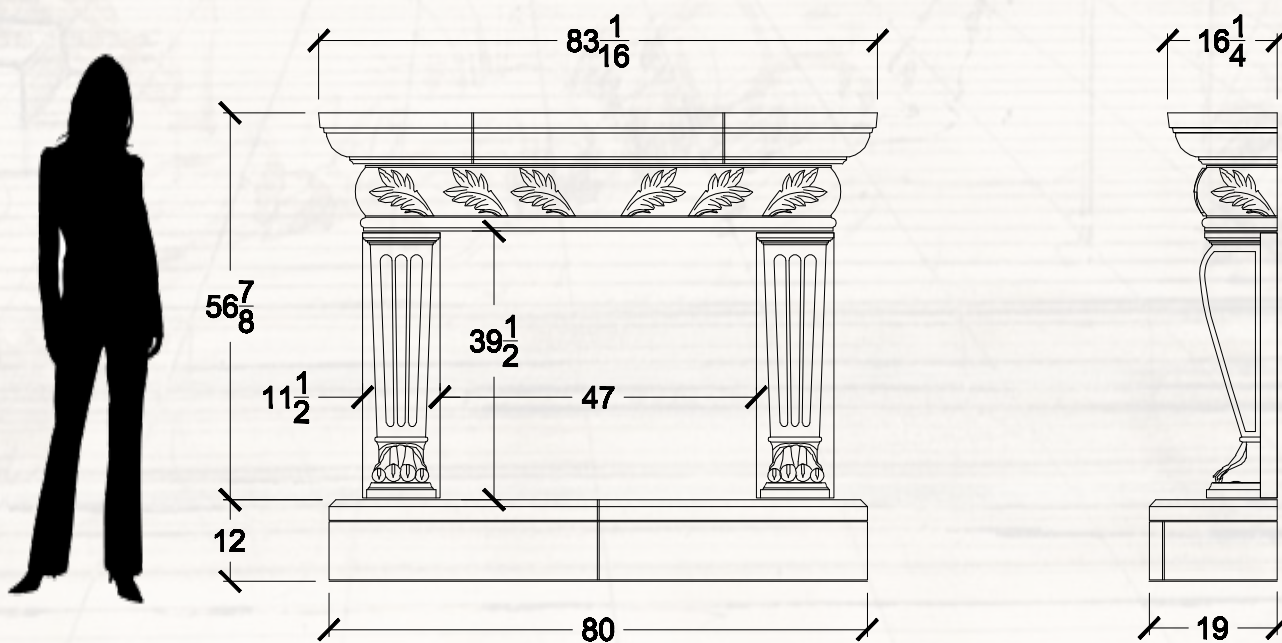

LOMBARDY





The Lombardy

The most ornate mantel in the Renaissance Cast Stone line-up also boasts great mass. This unmistakable statement demands the attention of your guests and always gets you rave reviews if placed in the right room.

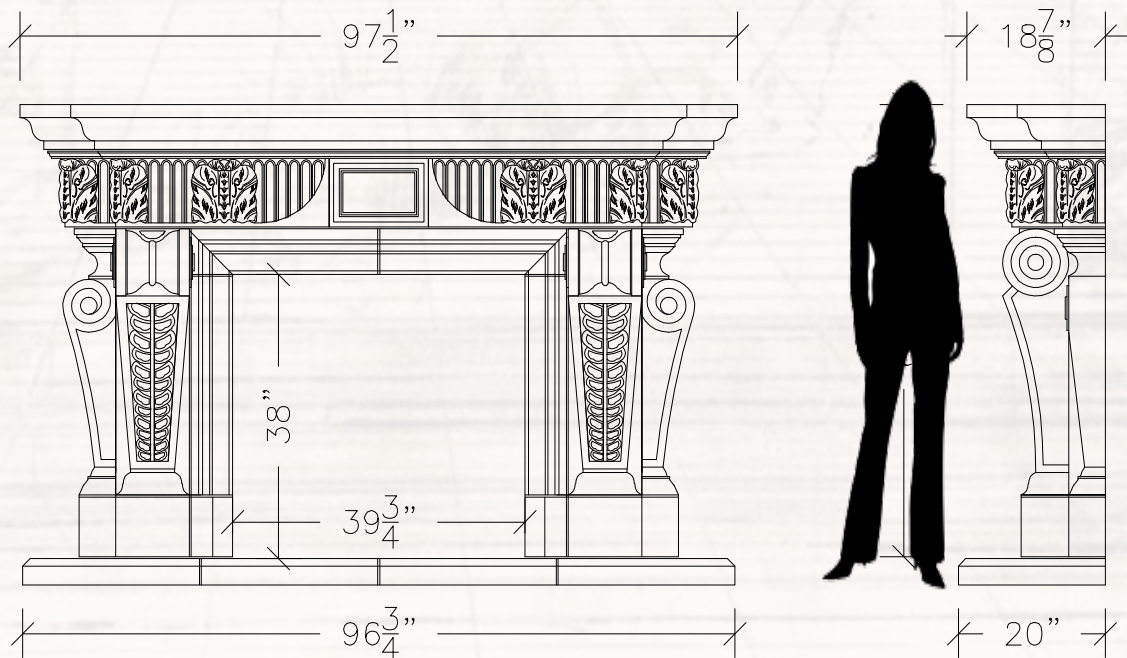

MARK ANTONY





The Marc Antony

Like it's namesake, this piece transforms your living space, demanding it's viewers to acquiesce to it's absolute and dominant presence.

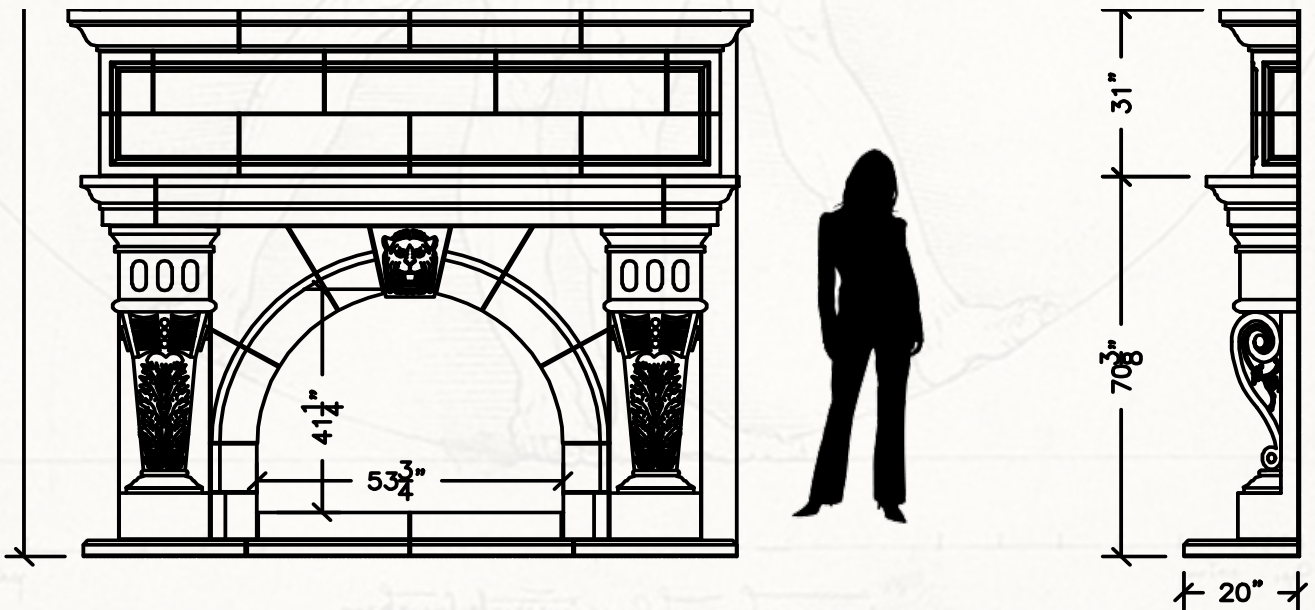

NICHOLE





The Nichole

"The victory of the people", or the bedroom or the study...or whatever room you need a win.

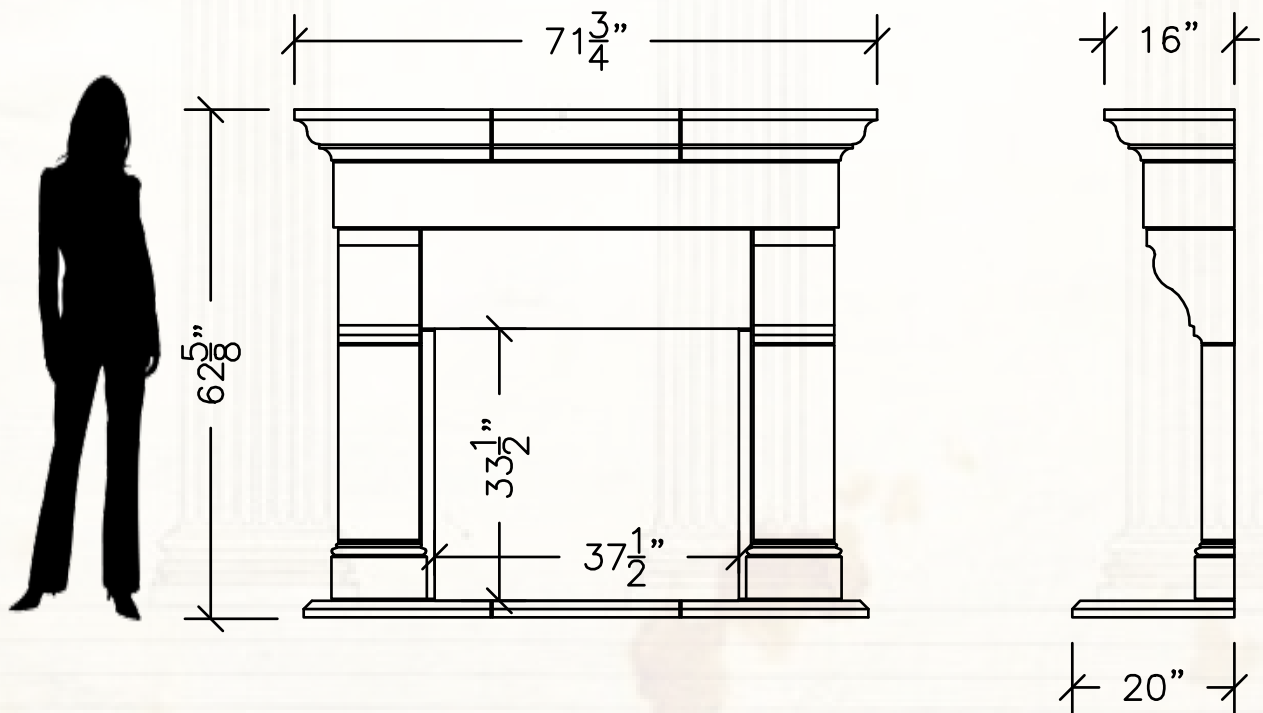

OXFORD





The Oxford

Deep, defined patterns around the arches and legs, interrupted by either a scroll or ornate corbel, the Oxford is defined by the great "City of Dreaming Spires" for the early advances in architecture.

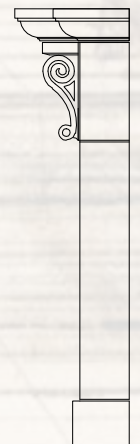
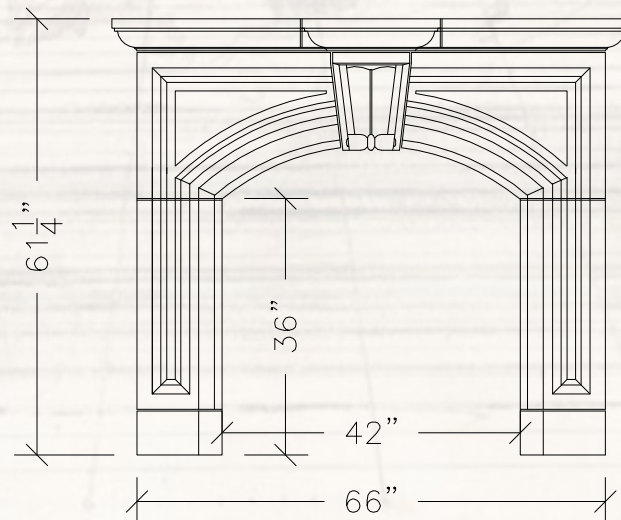

8" ⁵⁷

P R E S T I T O





The Prestito

To “borrow from”, The Prestito borrows ideas of designs from other designs combined to make a statement all it's own! Columns for legs, the radius filler and the sharp mantel adds clean and precise to any room.

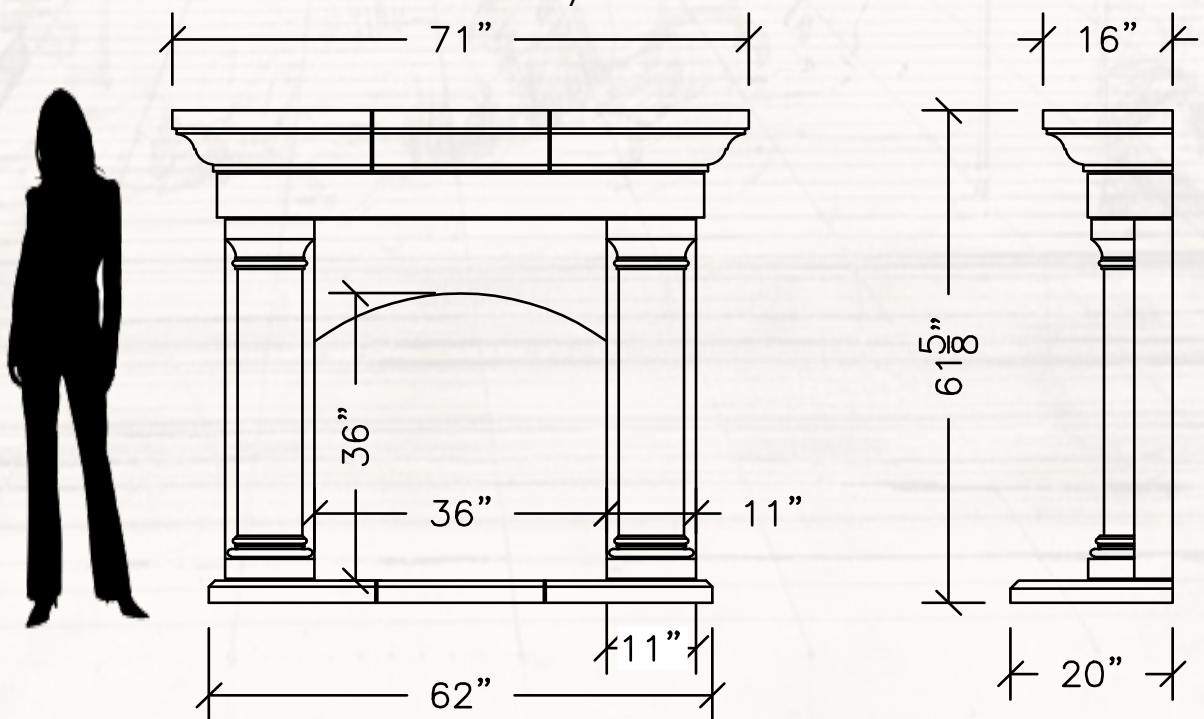

PRIMA DONNA

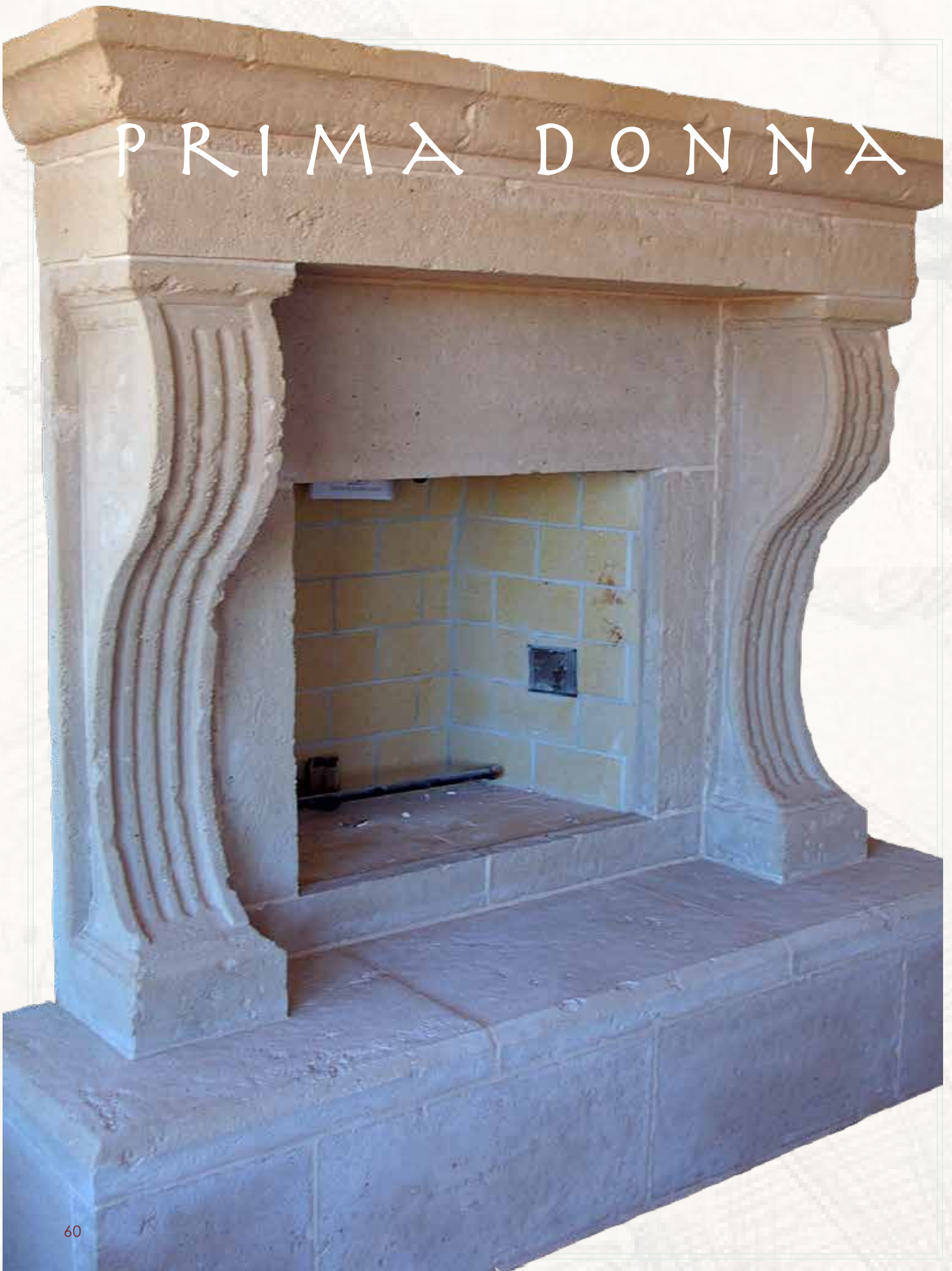



The Prima Donna

Like the name evokes, this petite mantel shouts for attention. Fluted, subtle curved legs, under a simple mantel and crown.

Shown left with our "Antique" Finish.

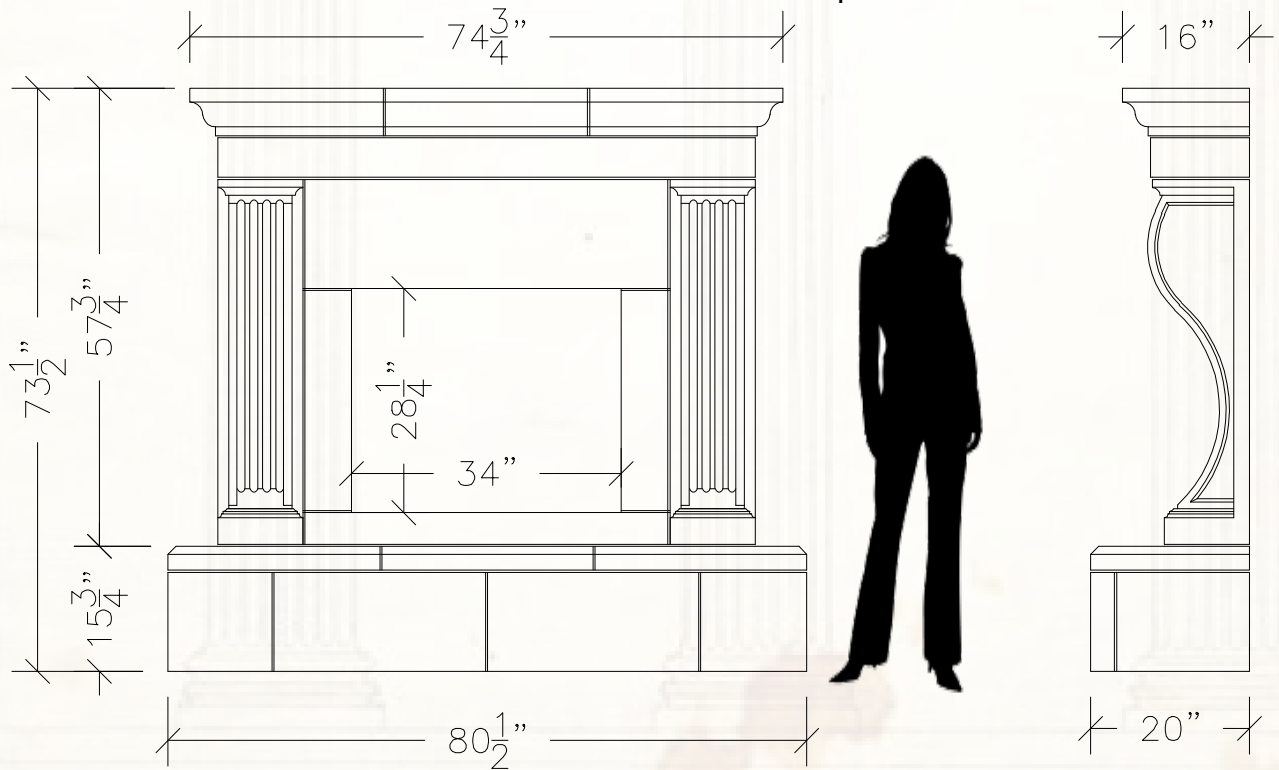

SETA PIETRA





The Seta Pietra

The name refers to silk and stone which is how this combination works so well together.

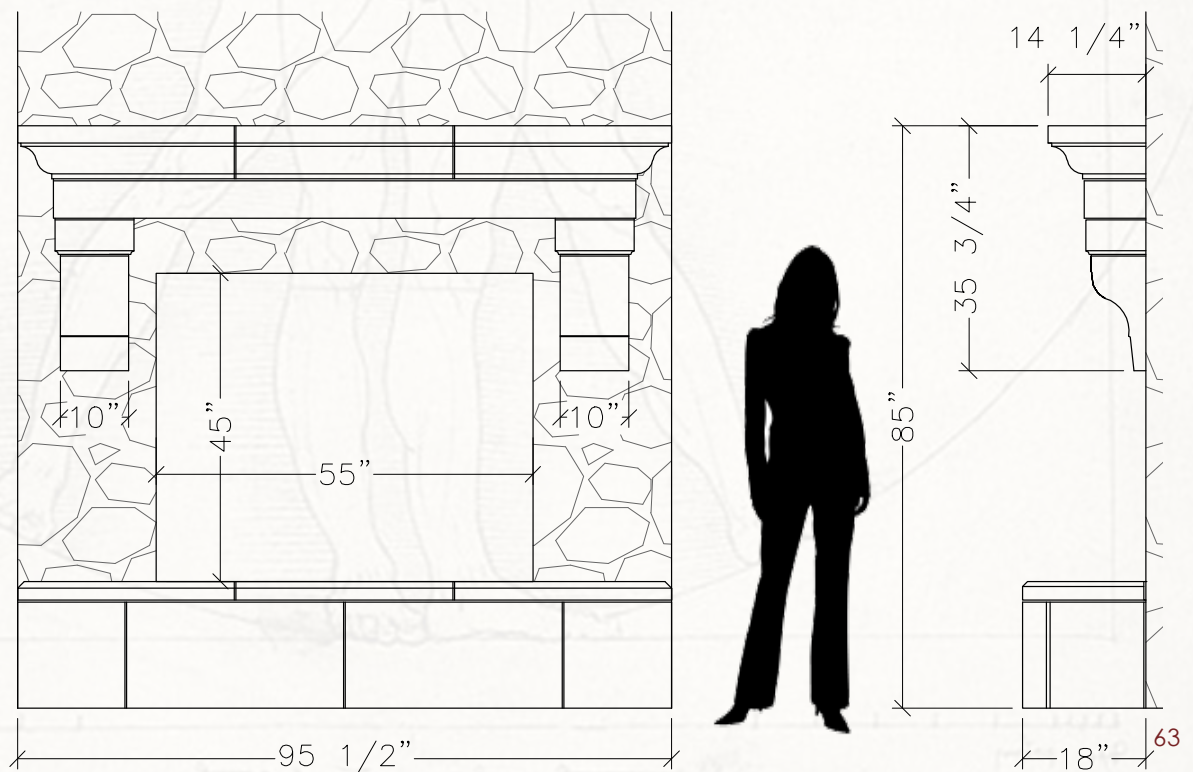

R O C O C O





The Rococo

“Very Ornate” in any country, the delicate tapestry of design in the Rococo is easy to fall for. A fitting mantel for a simple room to add complexity and detail.

(Pictured above in the Rococo Classic design with a straightened header in place of the curve pictured left)

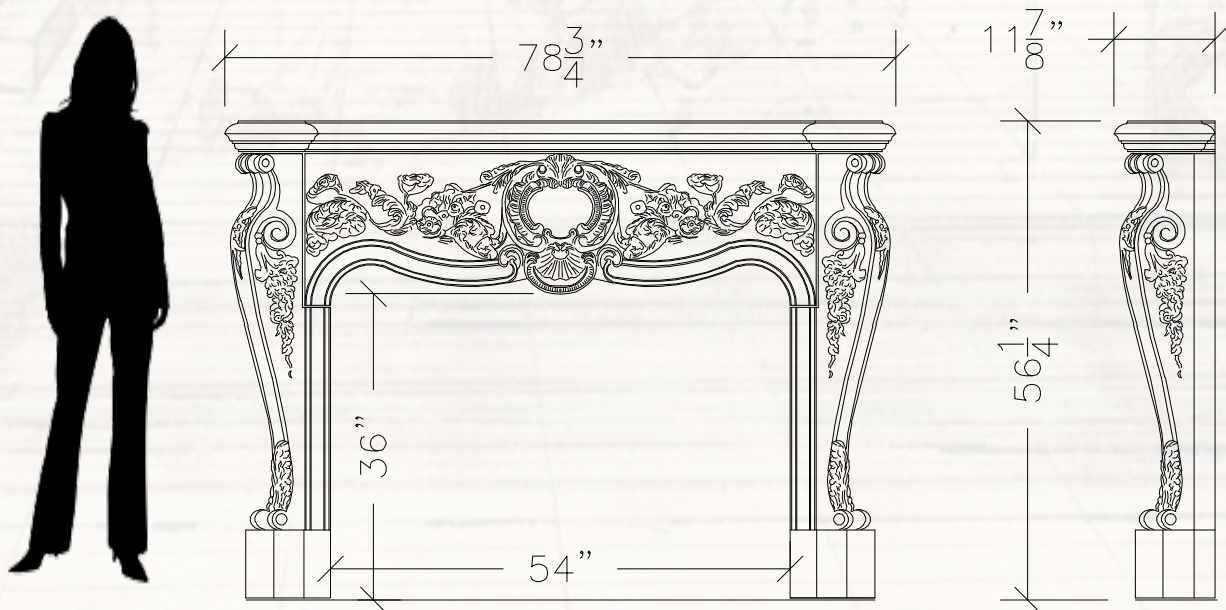

SATONE LUCIDO





Satone Lucido

Literally, "polished stone" these beautiful polished panels come together to create versatile shapes and lend itself to an industrial / contemporary decor. With or without the heavy duty bolt pattern this fireplace will get your attention.

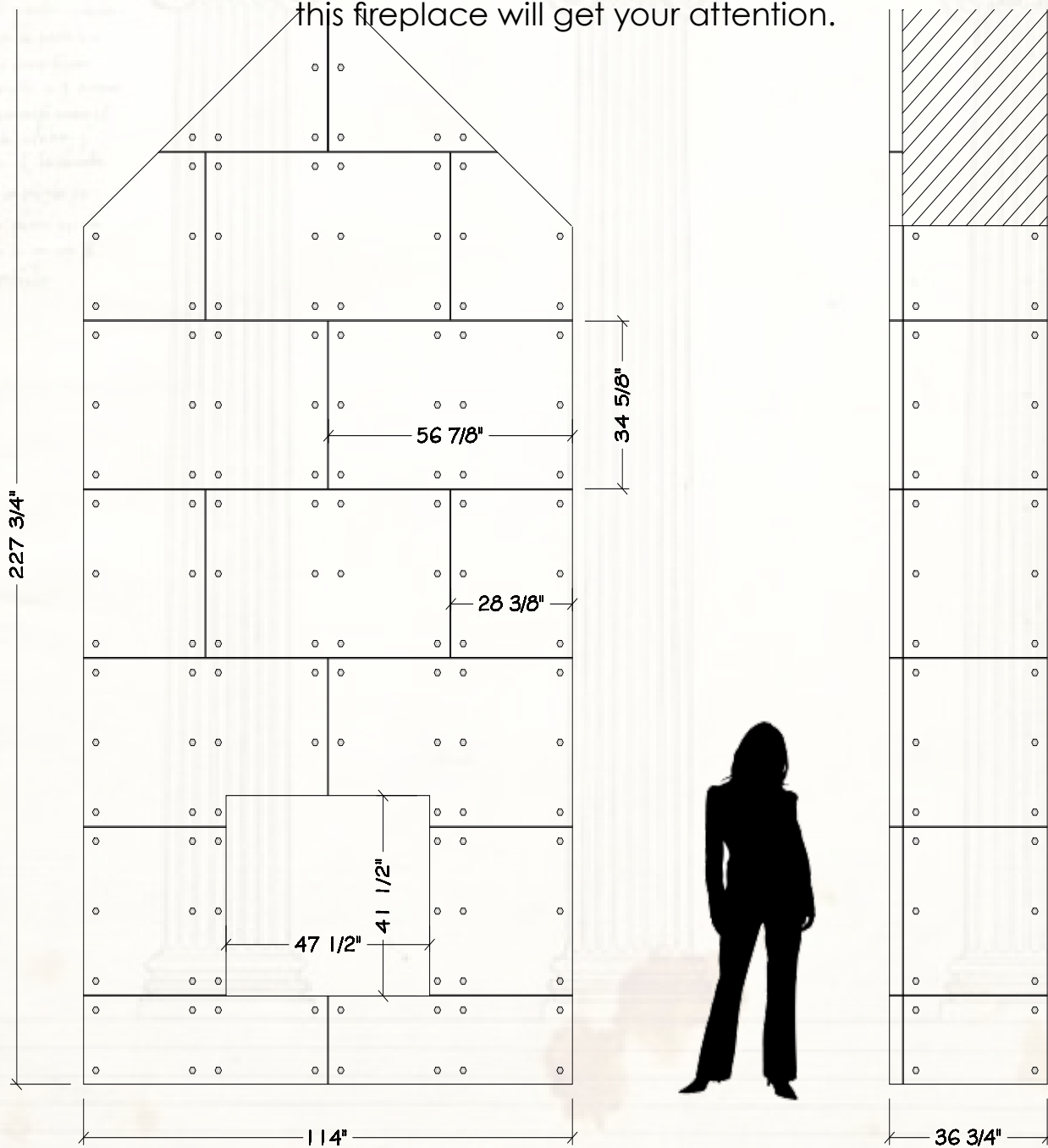

SCINTILLE





The Scintille

A less is more approach to get “sparks” to fly and eyes to dazzle upon this beautiful, delicate design.

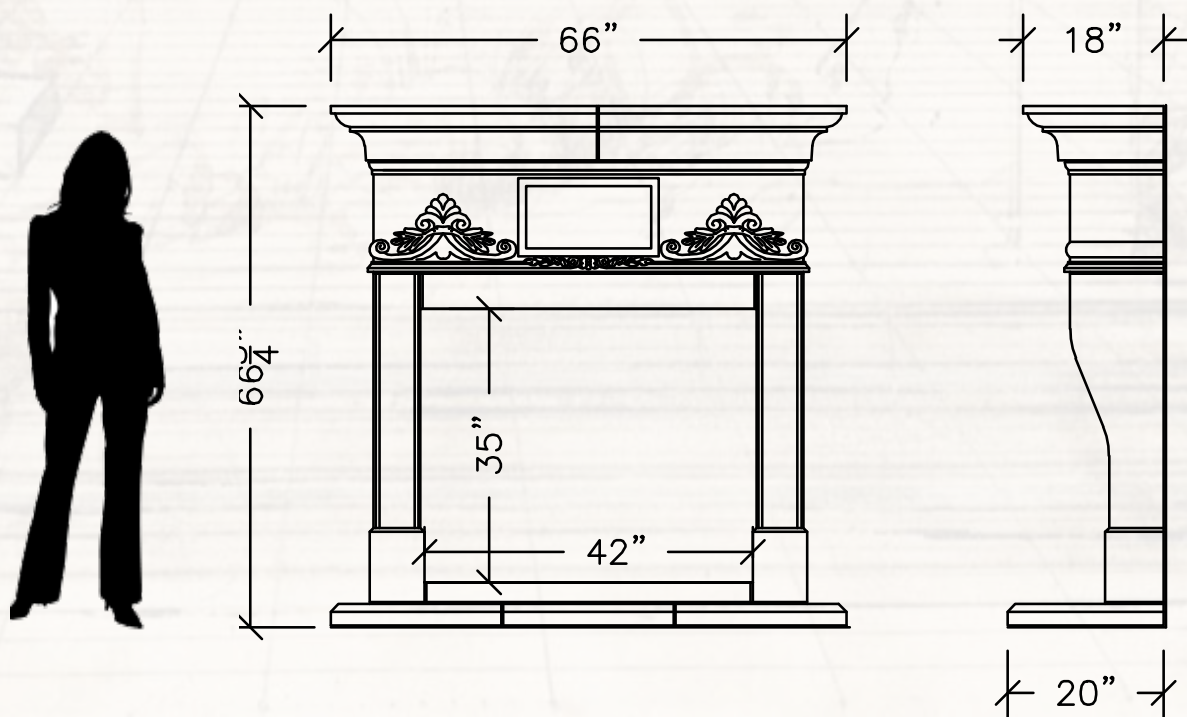

SEVILLA





The Sevilla

Fanciful Moorish architecture is the articulated Islamic architecture of North Africa and parts of Spain and Portugal influencing this piece throughout.

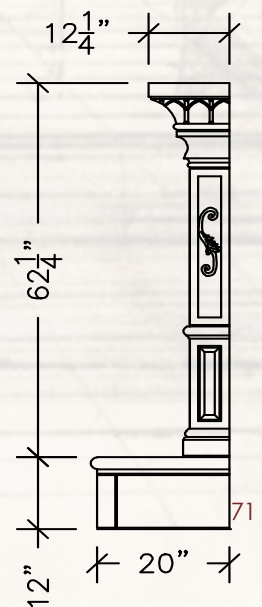
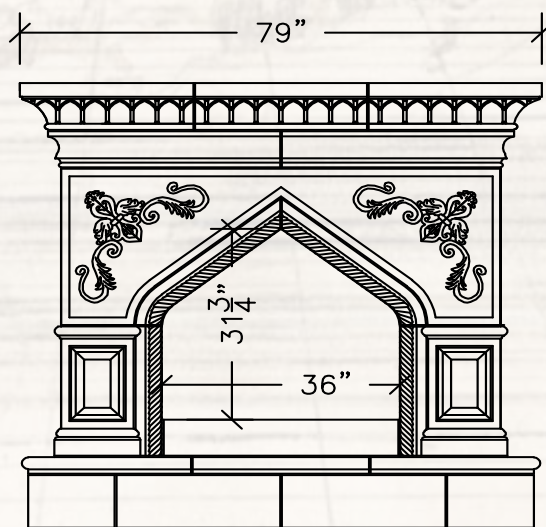

SHELBY





The Shelby

With the mantel topping out at over 6' tall, The Shelby is one of our largest and most complex. Rope column legs, defined box complexity and sheer mass. With choices of 2 different insert panel designs. This one can fill a large space with an impressive wonderment.

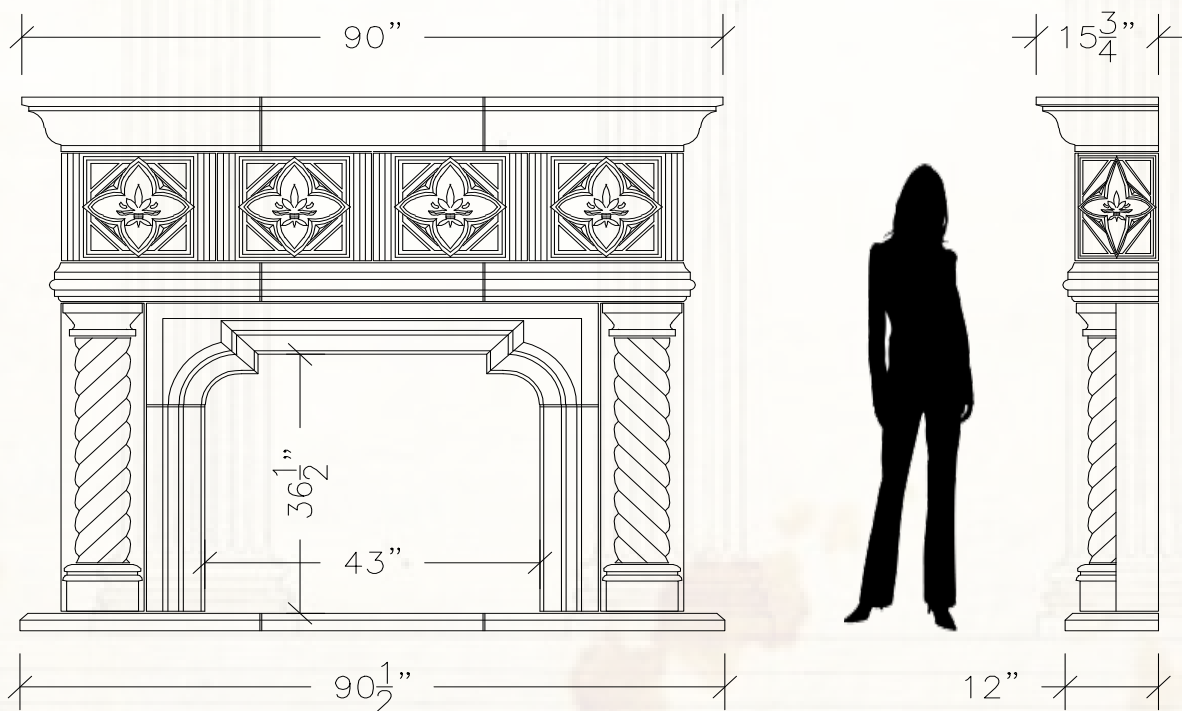

ΣΠΑΓΟ ΚΟΛΟΣΙ





The Spago Colosi

A massive Mediterranean design standing over 6 feet tall from floor to the top of the mantel. Rope legs, versatile radius or straight filler pieces and the ability to shrink to a smaller product like the picture above, makes for a popular choice.

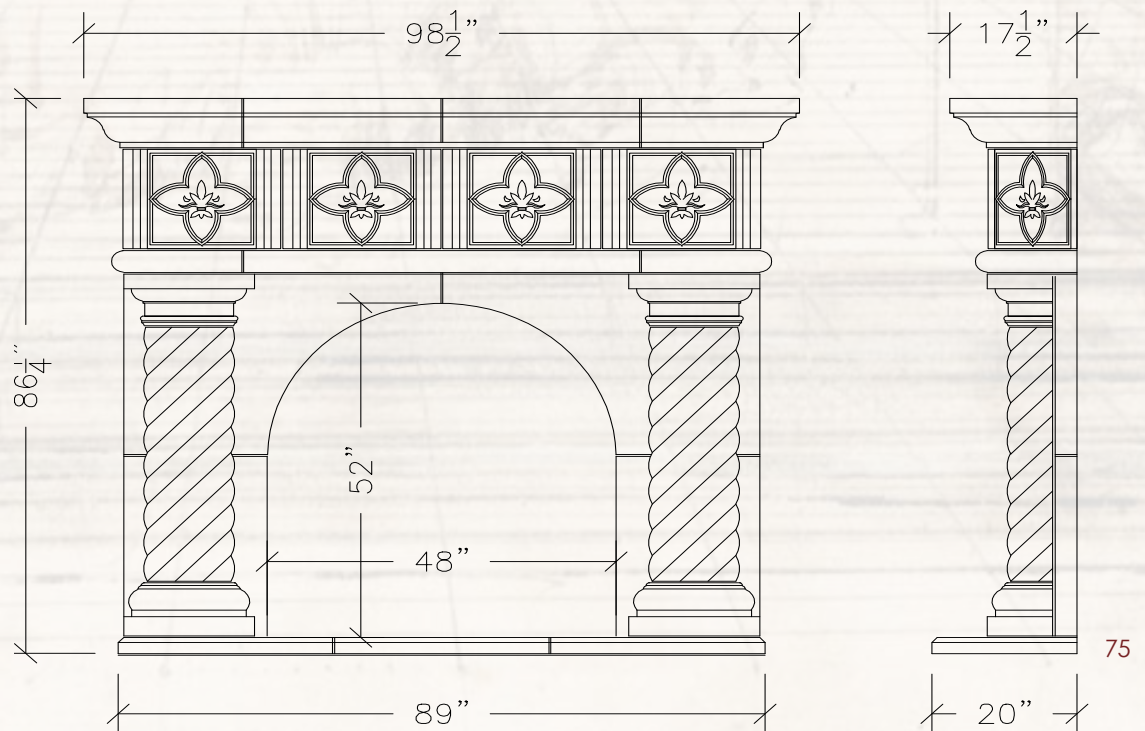

SPIGATO AL PIETRE





Spigato Al
Pietre

Quite literally,
"Herringbone in
the rock"

This amazing
tandem beauty
can be placed
without it's rock
counterpart,

but was
designed to
work with other
types of stone
or masonry,
which gives
it's intricate
designs a
canvas on
which to shine.

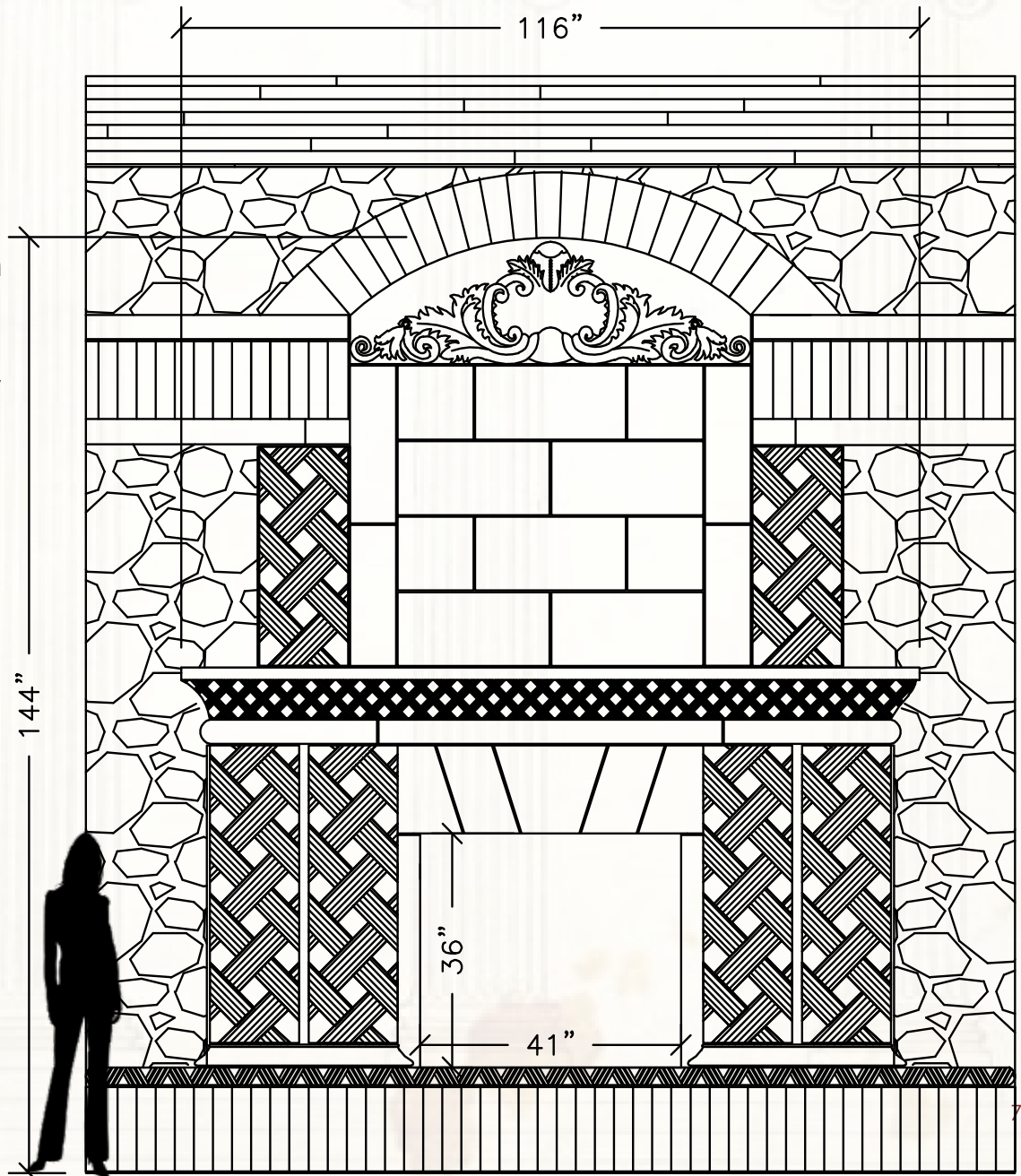

SOPRESA





The Sopresa

Our little "Surprise" mantel that can fit anywhere, ideal for remodels or places with little support like upstairs fireboxes. Additional corbel designs and the ability to change flat panel configurations make this the most flexible cast mantel out there.

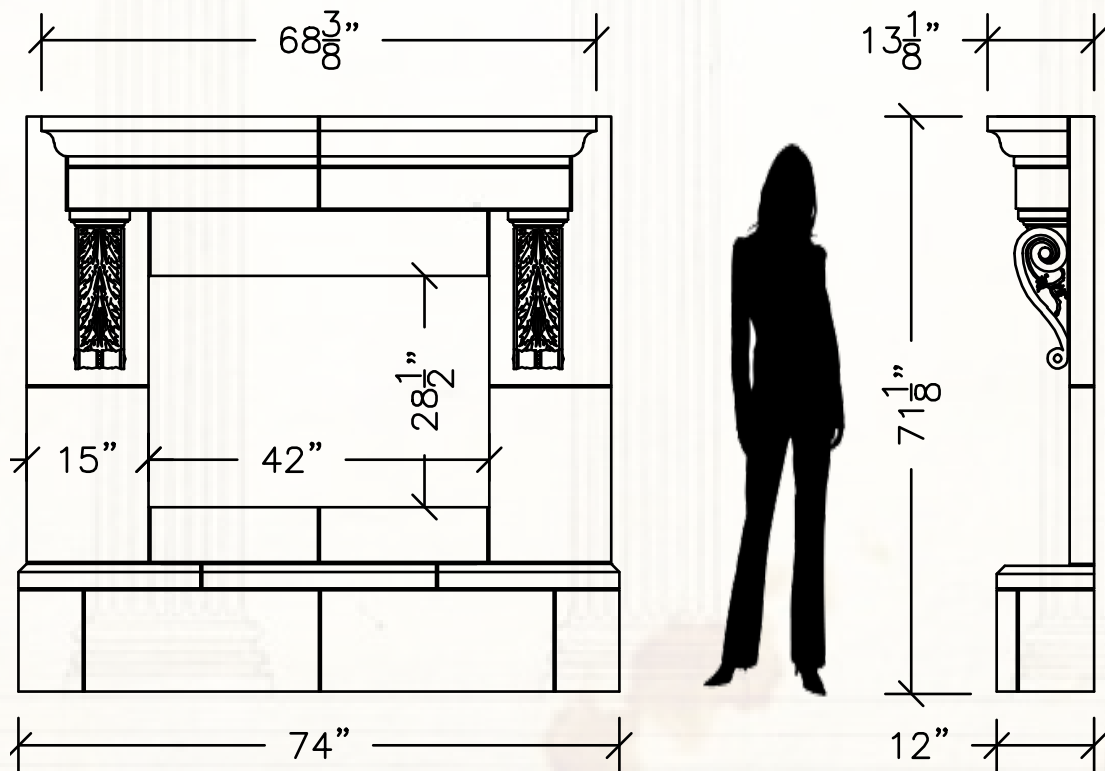

SOSTENERE





The Sostenere

Corinthian column style legs and attention to the smallest detail makes the Sostenere capture the eye and the imagination! It will take your guests more than one glance to appreciate the exquisite design.

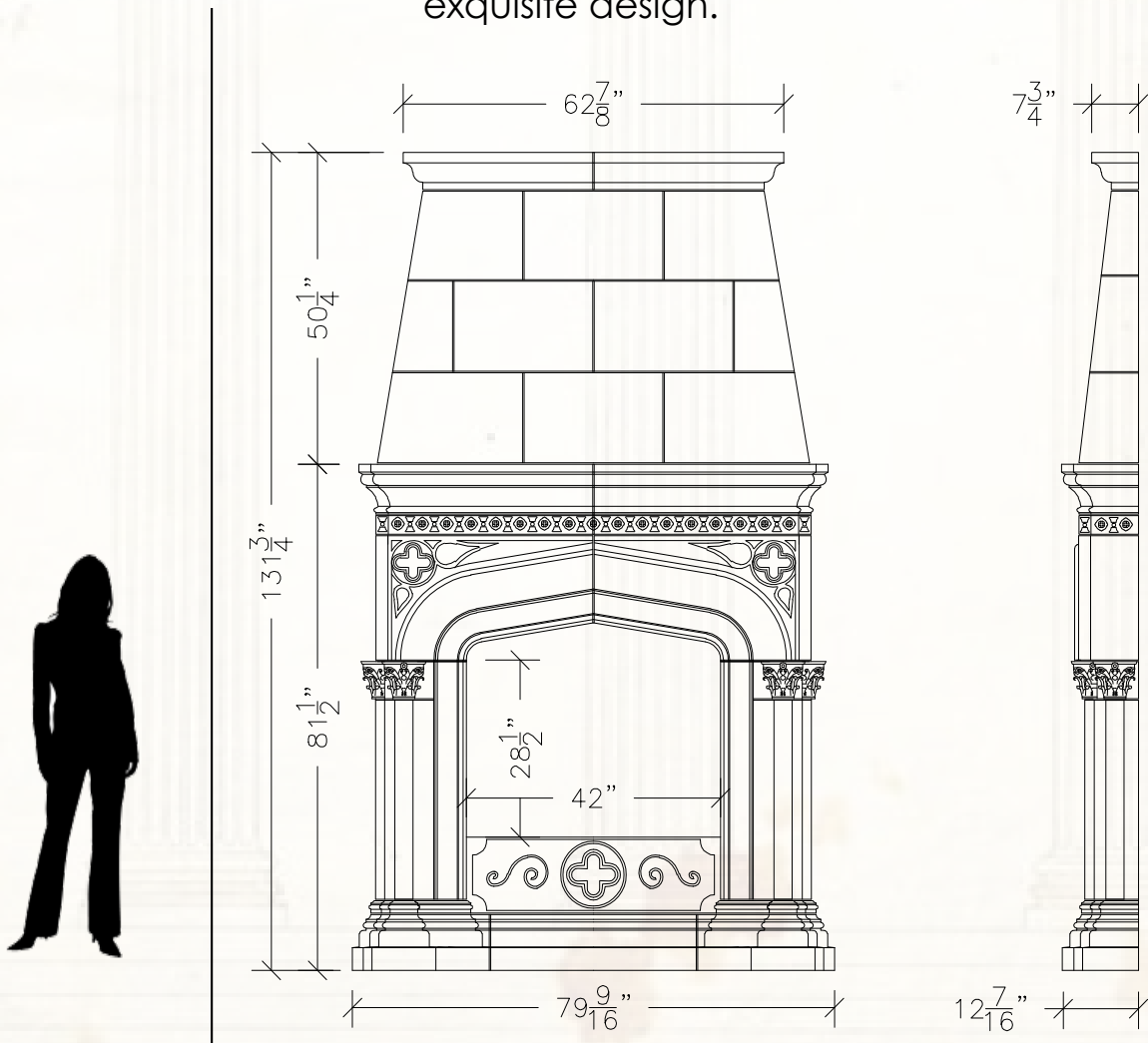

TERRITORY





The Territory

Seemingly understated at first glance. Upon further study, The Territory reveals it's hidden charm of clean lines and simple subtleness.

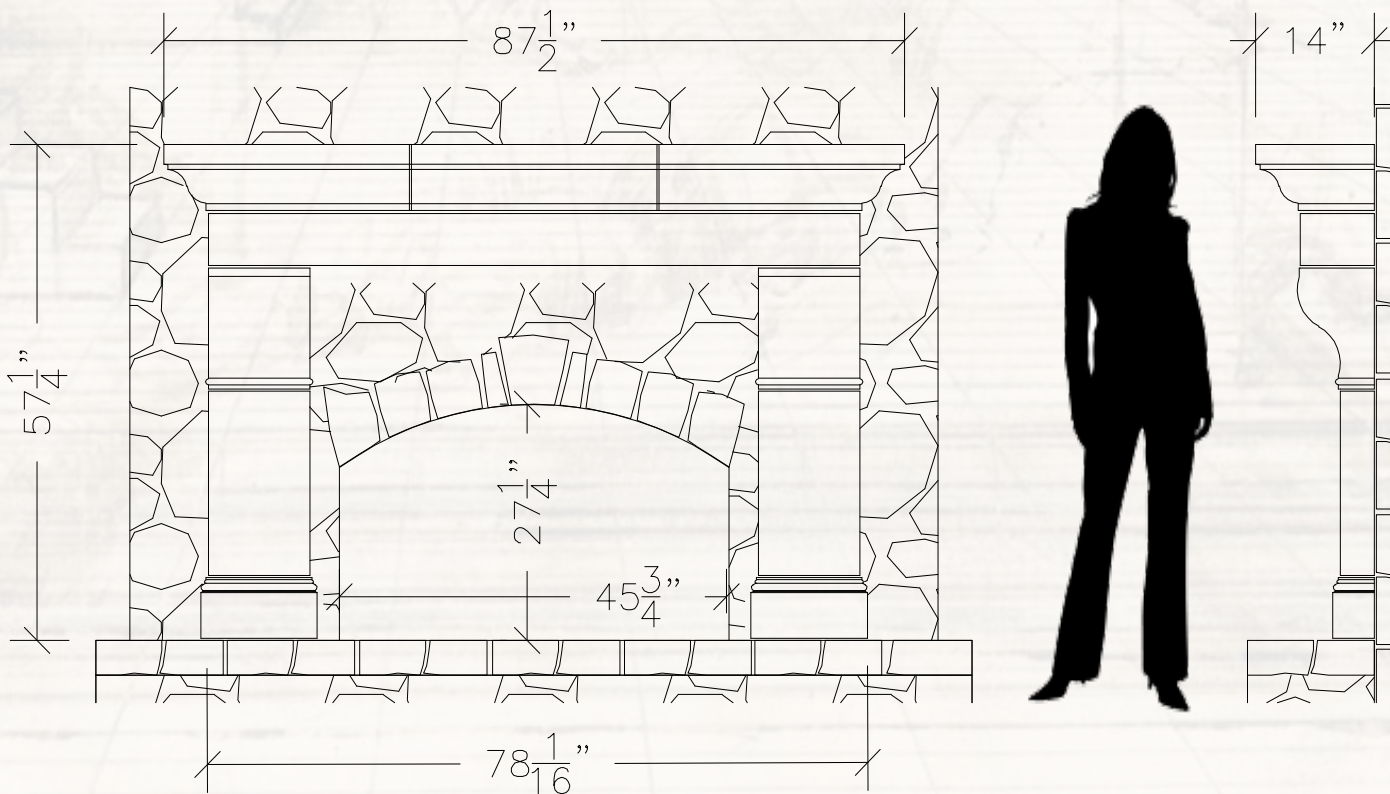

TURIN





The Turin

Inspired by Turin architecture, curving in many directions like the boulevards and grand squares such as Piazza Castello and Piazza San Carlo.

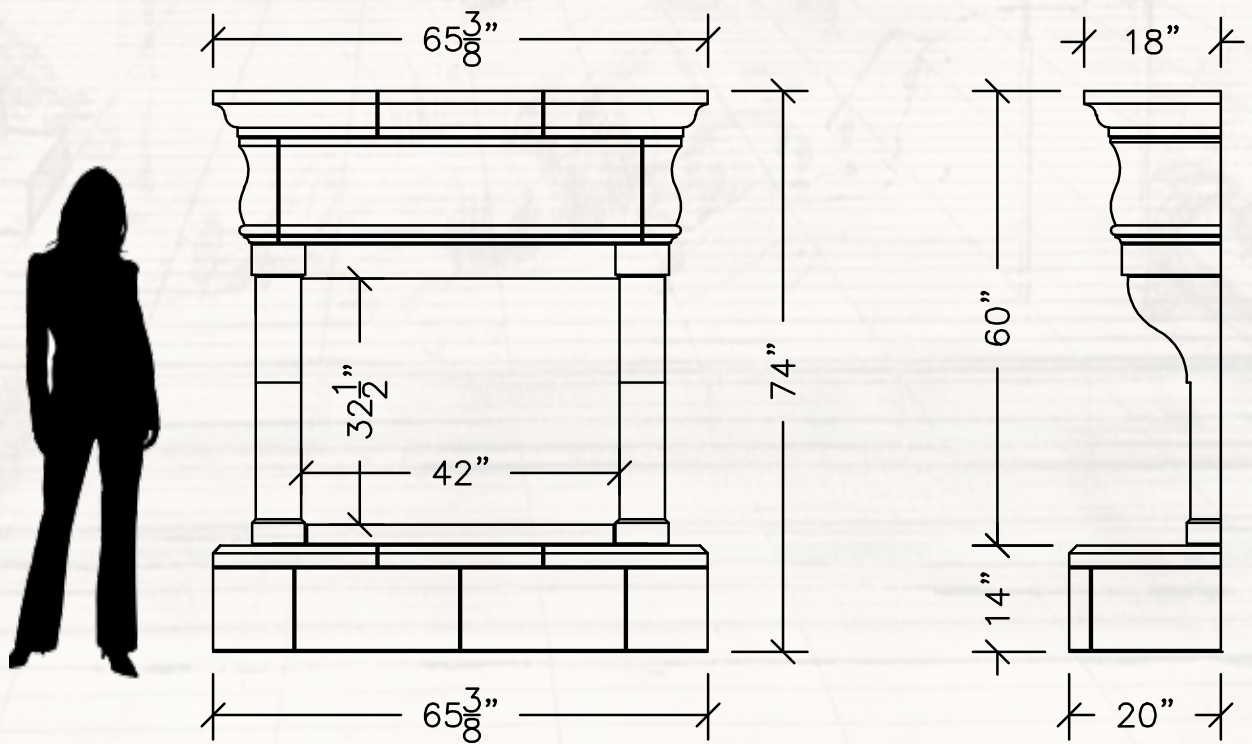

TUSCANY





The Tuscany

Third in our series, popular for its smooth appearance. Old style charm is written all over this mantel. A very versatile product capable of spanning many different decors.

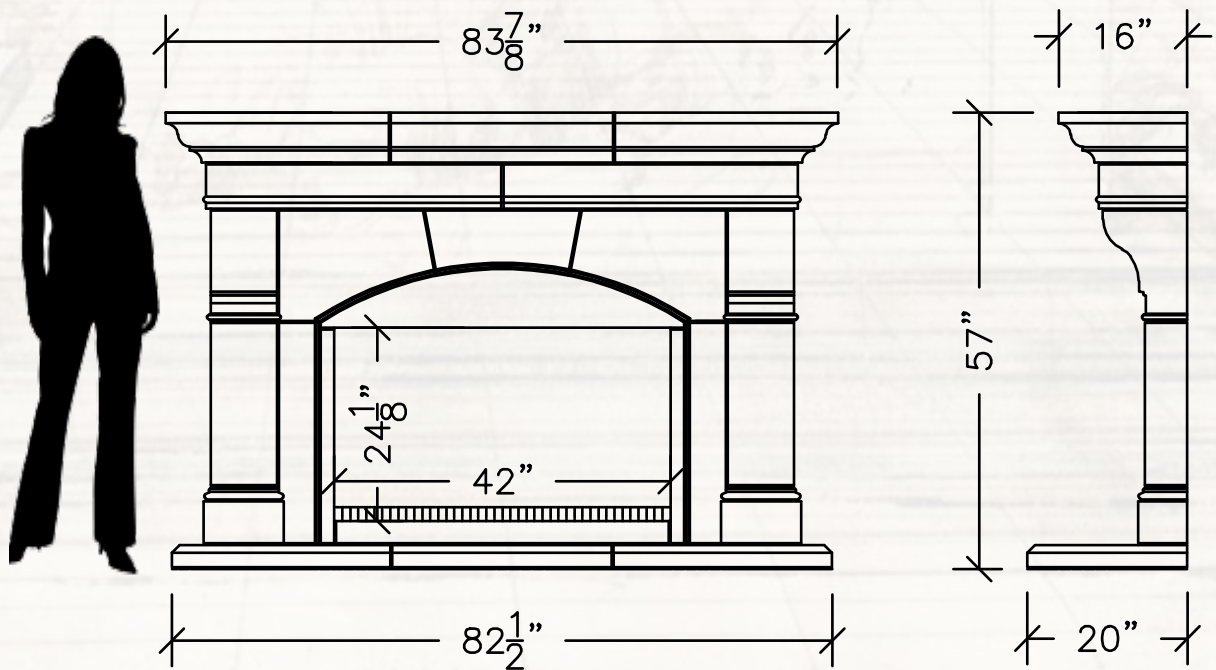

VERSAILLES





The Versailles

Inspired by the birthplace of the Louis XIV Monarchy, a classic Louis with refined, elegant craftsmanship.

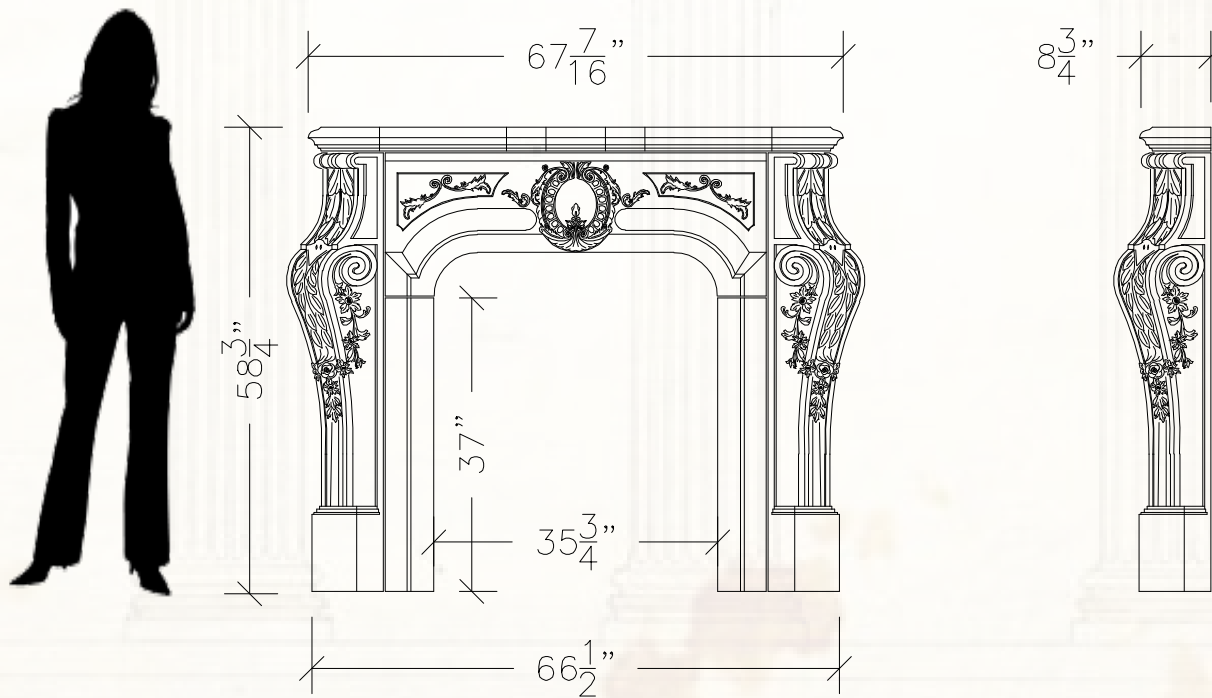

WISIAN





The Wisian

First in our series of the Ode to Italy, the bullnose banding makes a ledge that defines the lines between the legs and mantel like no other.

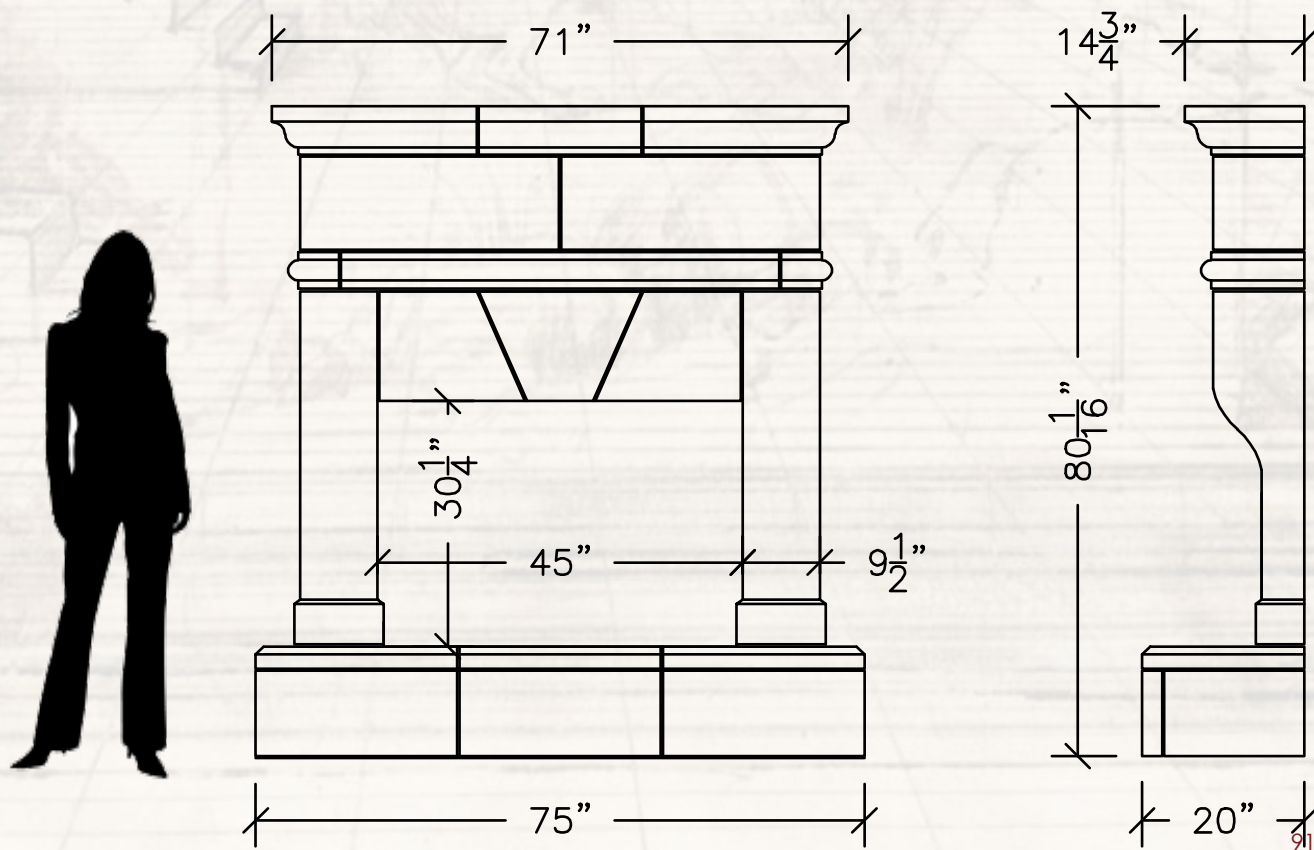

WALDORF

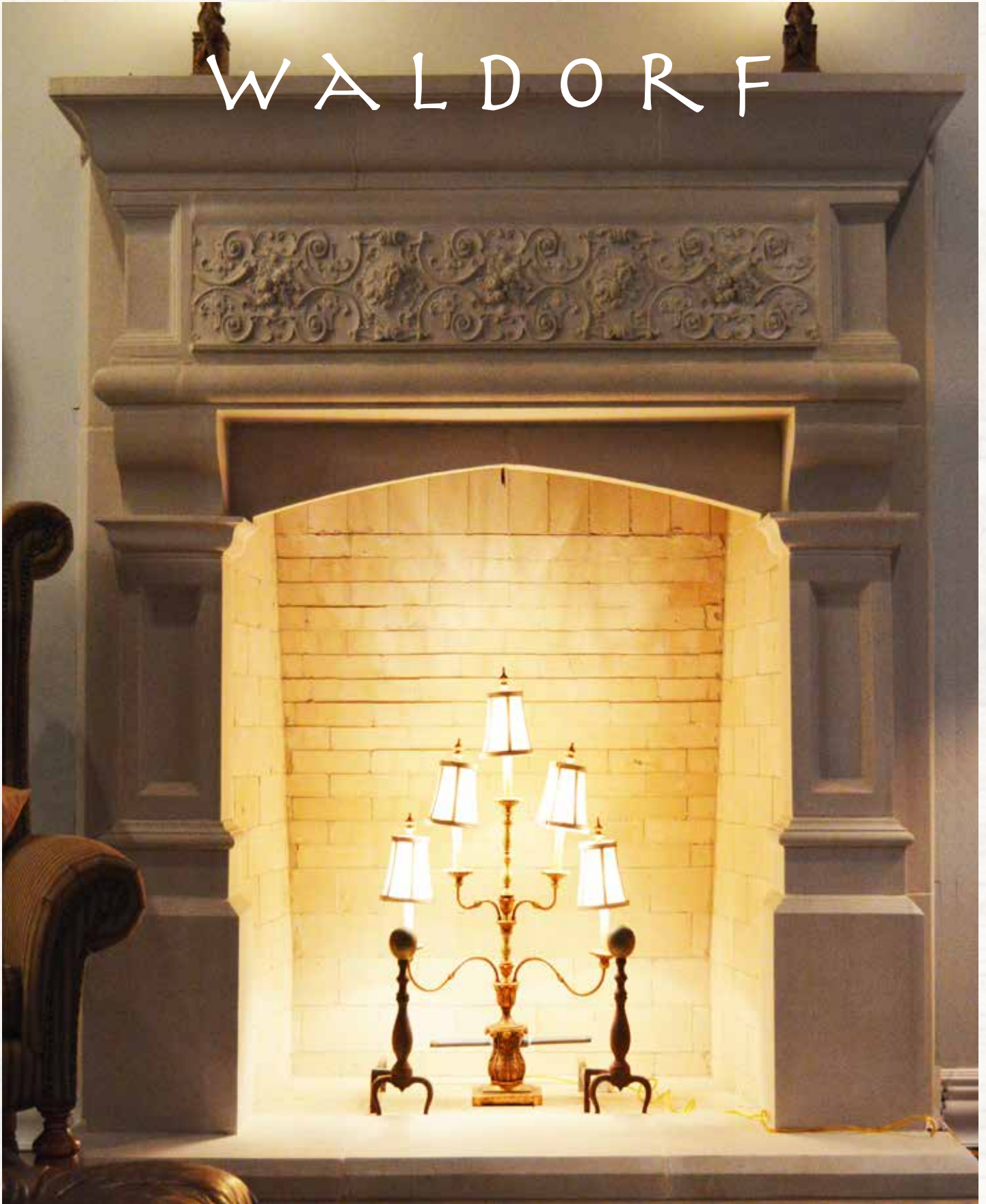



The Waldorf

A Rudolph Steiner inspired mantel that has learned from other pieces to have it's shapes and intricacies creatively carved out to form it's own identity.

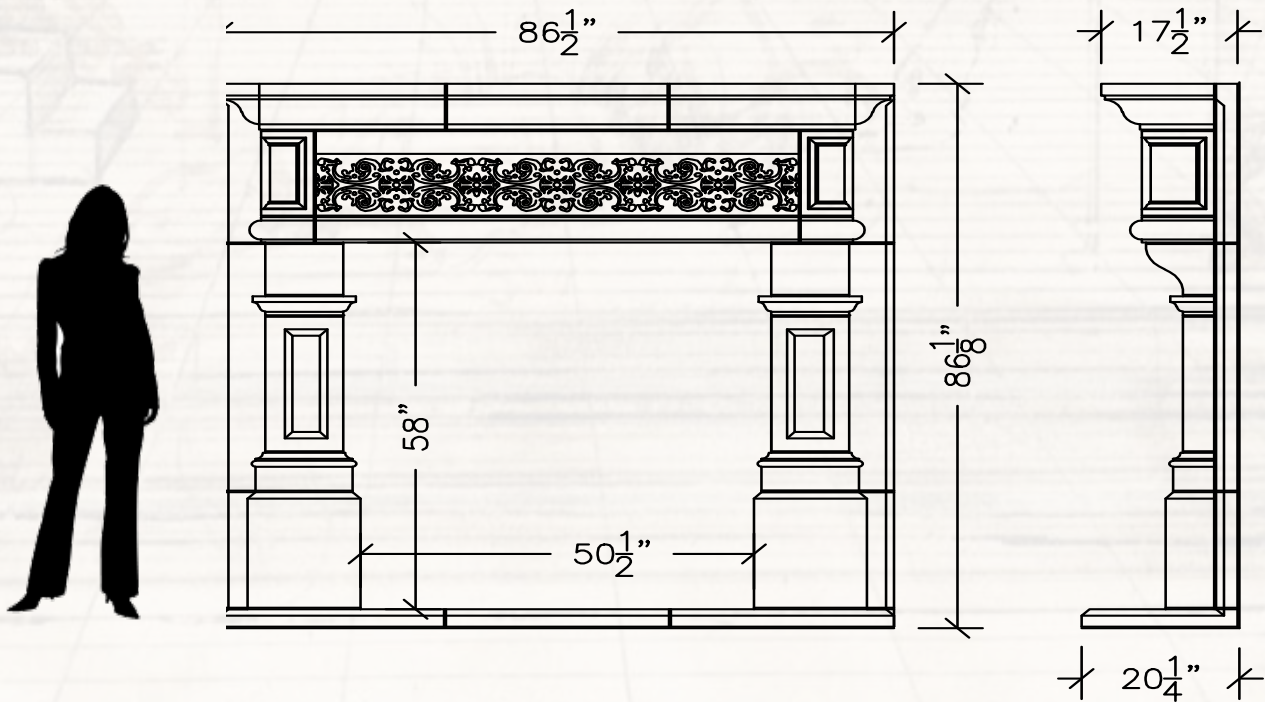

KITCHEN

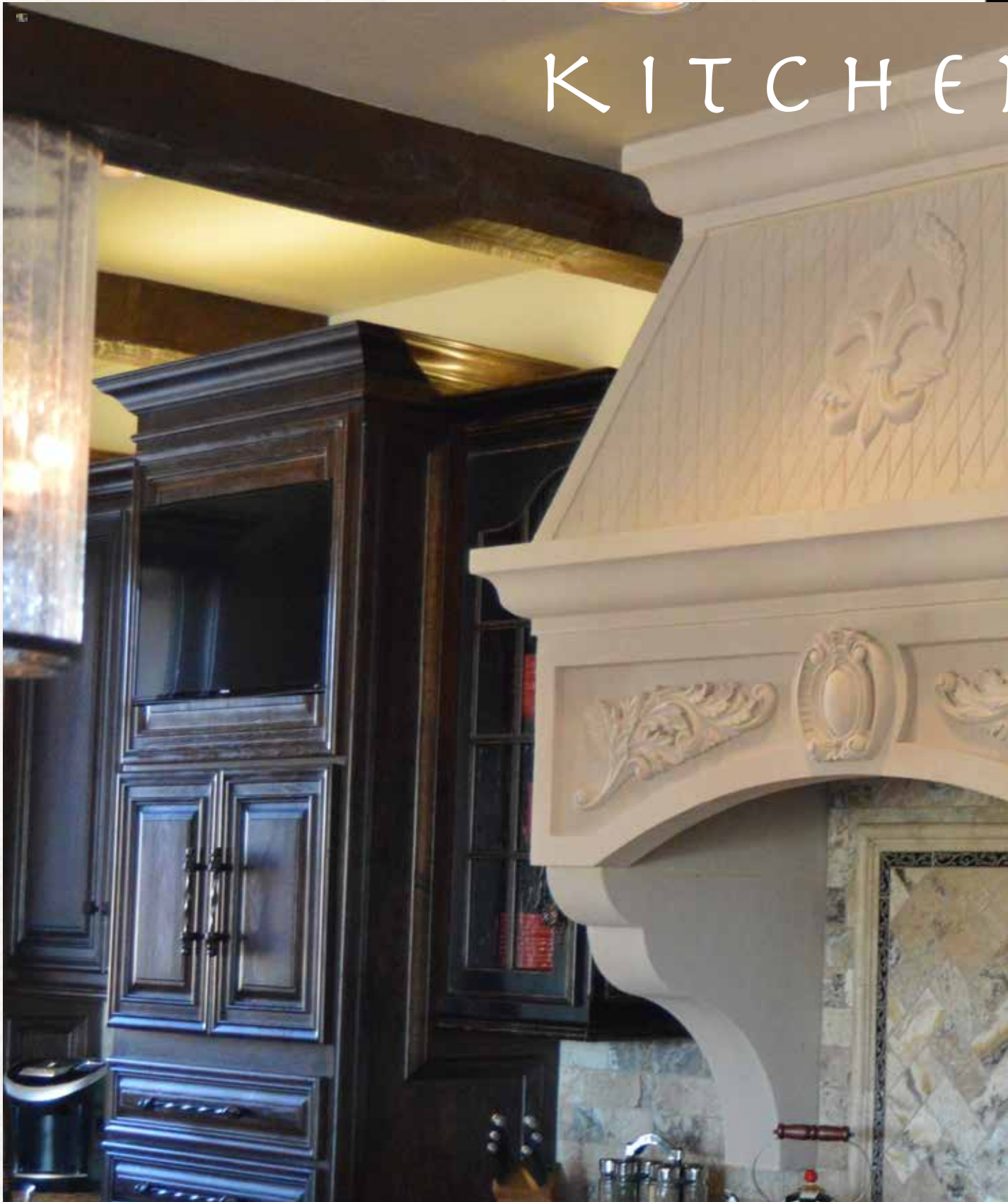

It is rare to find an item you can add to today's modern kitchen. The kitchen hood is one of those items. In the pages that

N H O O D S



men that can inspire "awe", but a Renaissance Cast Stone
at follow, see if something we have inspires you.

BELLA CUCINA

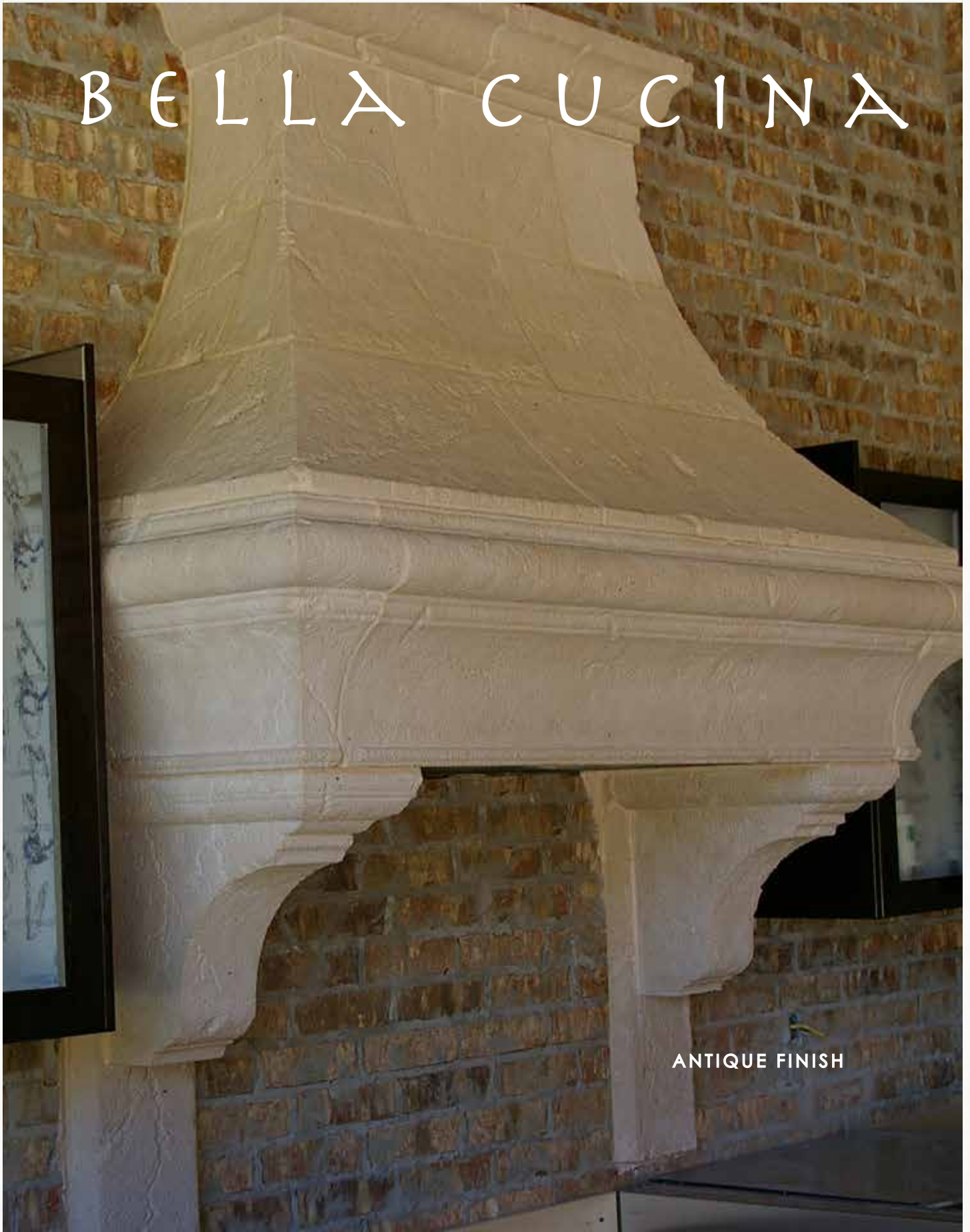

ANTIQUE FINISH



HERE W COPPER

Bella Cucina

"Beautiful Kitchen", The Bella Cucina certainly does it's part to add warmth and charm! An alarming piece that draws you in and asks, "what's for dinner?"

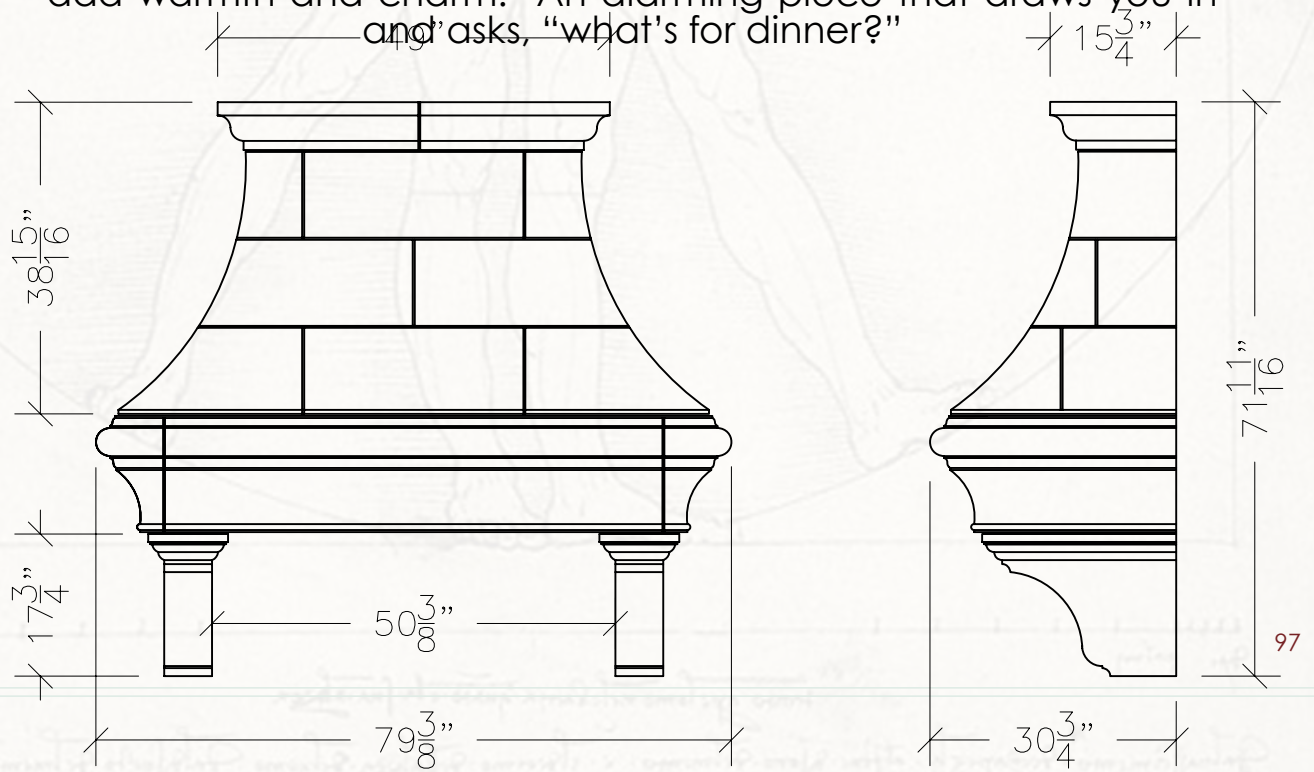

BELLA COMPANA



PLASTER AND WOOD



Bella Compana

“Beautiful Bell” Bella Compana a plaster kitchen hood, is open to different accent pieces. This flexible hood can use wood or plaster trim to accent the bell and the top.

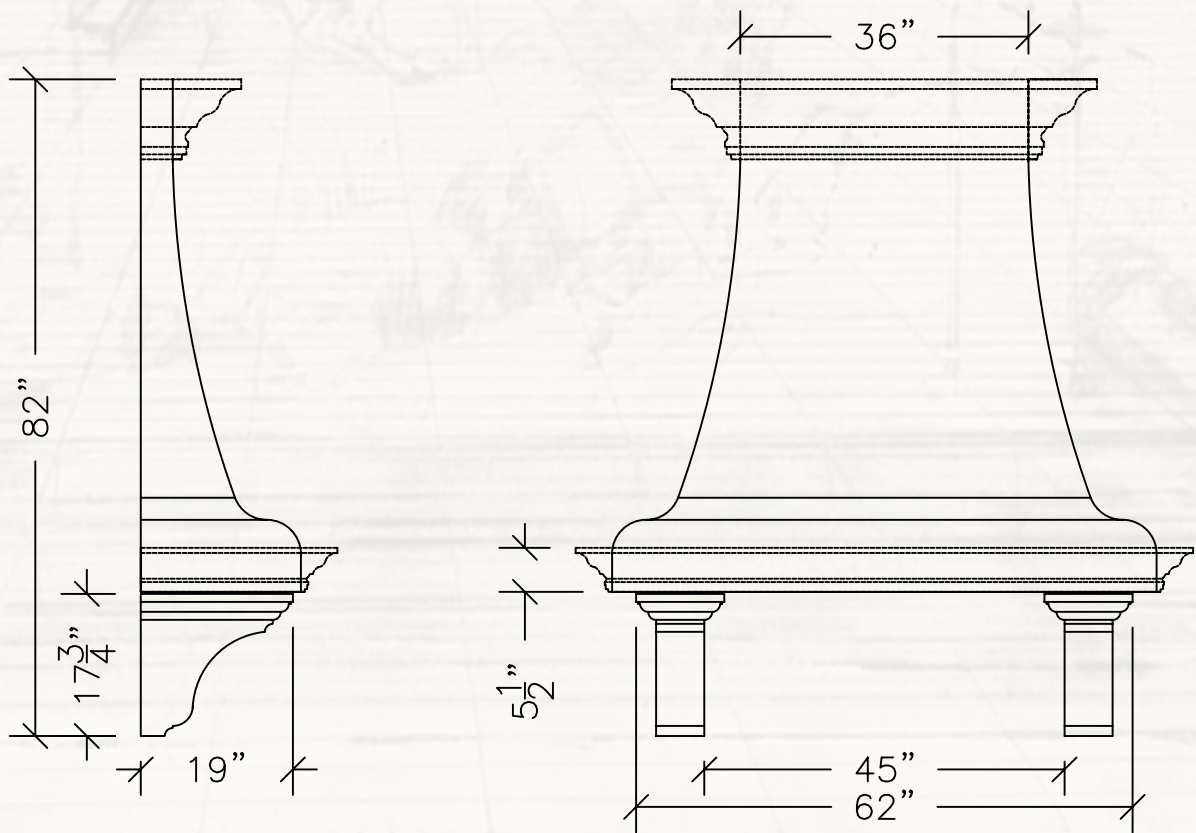

COMPAGNI





The Compagni

A stone mantel that is a "friend" to other upper stylings. In this picture, the upper section was tiled, but could also be a host of other textures.

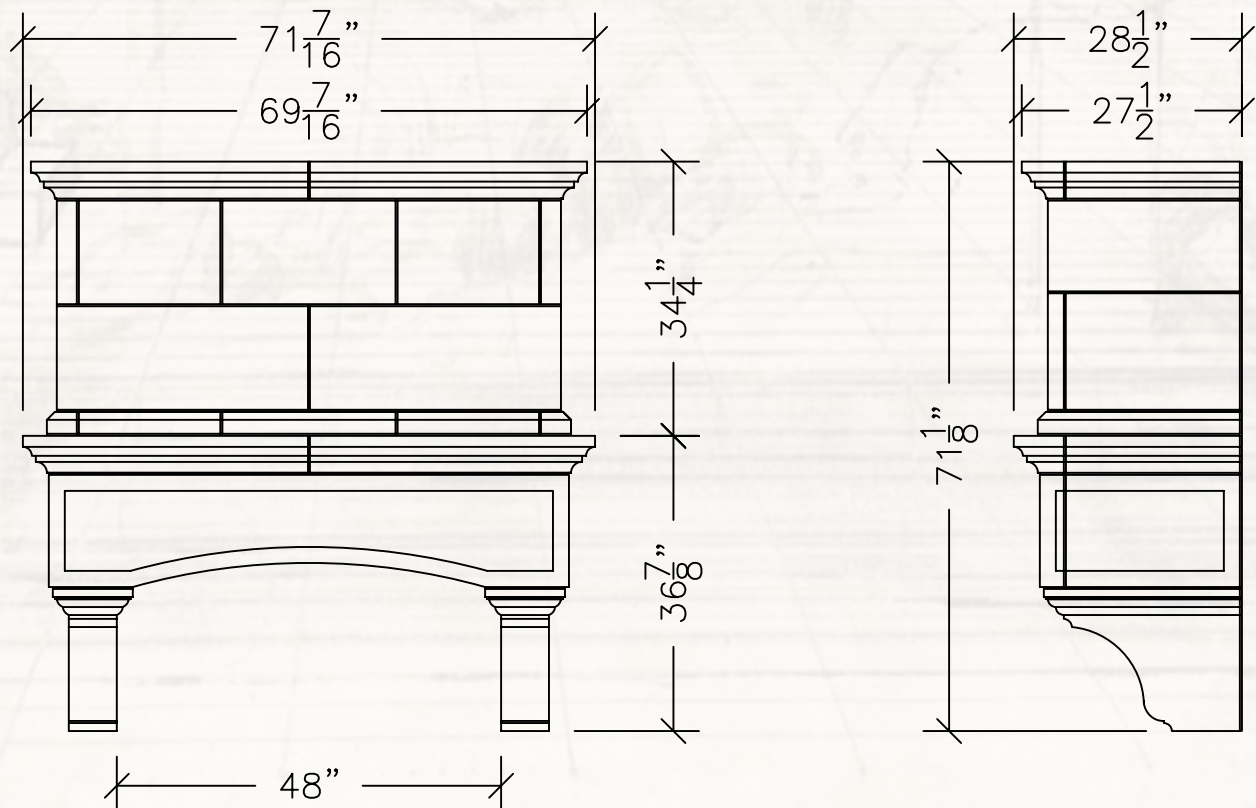

DAMASCUS





The Damascus

Drawing from it's ancient city's namesake, The Damascus takes it's shape and textures from one of the oldest continually inhabited cities in the world.

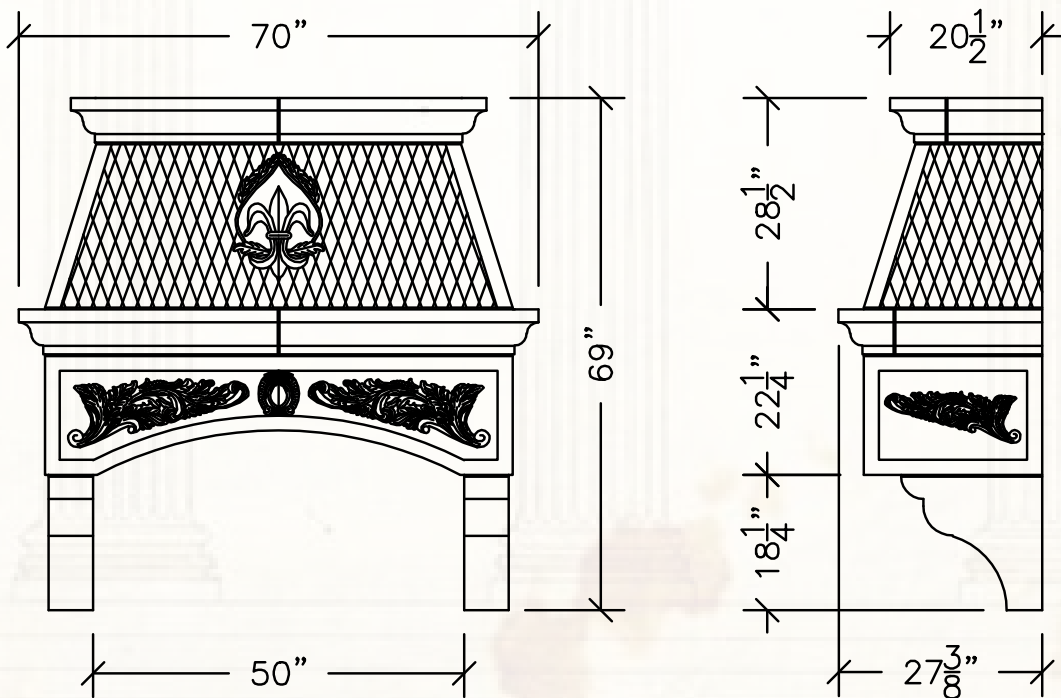

D A M E





The Dame

Meant for knighthood, this curvy, statuesque mantel borrows form from the prestigious name afforded women equal to knights.

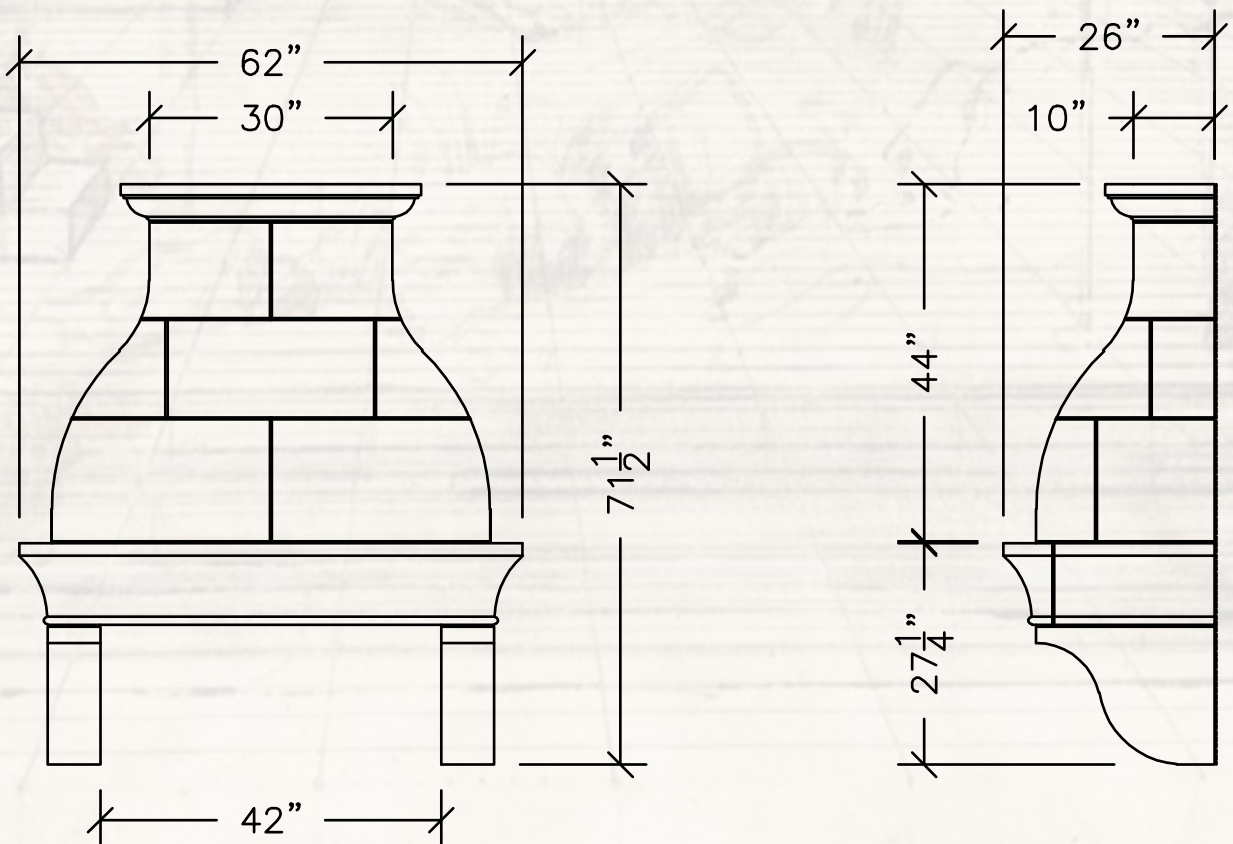

FILIGRANA





The Filigrana

Made exclusively from plaster, this mantel borrows its name from the filigree design styles adapted by the French from early Egyptian designs. Lighter than stone, and provided in white plaster, the Filigrana can be colored to suite any decor!

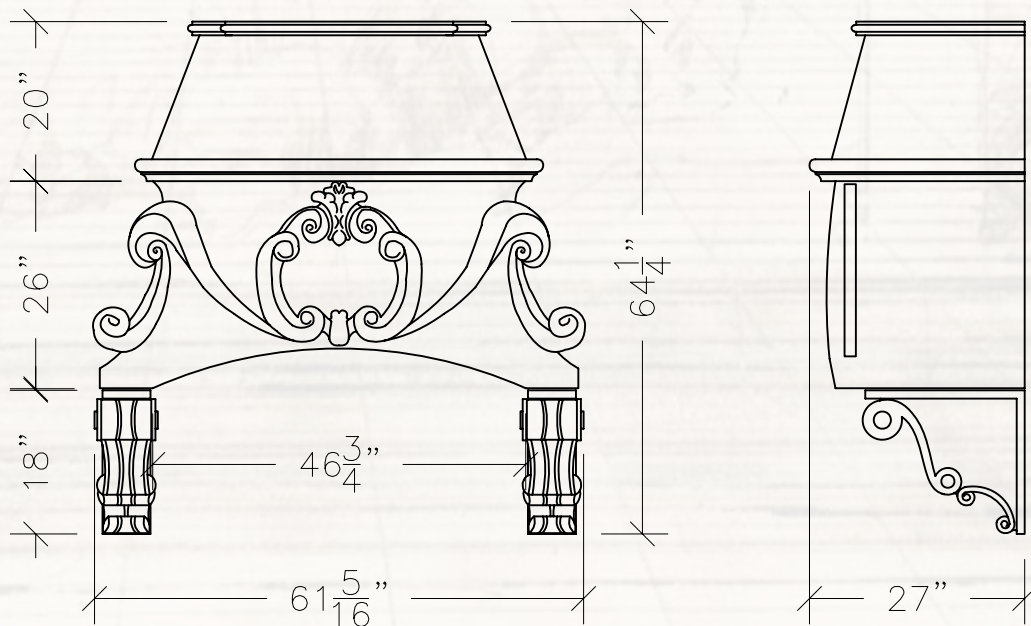

FLIRTARE





The Flirtare

A true "tease" in the kitchen. Fancy, but not too, sturdy but delicate, with a little sophisticated whimsy to finish.

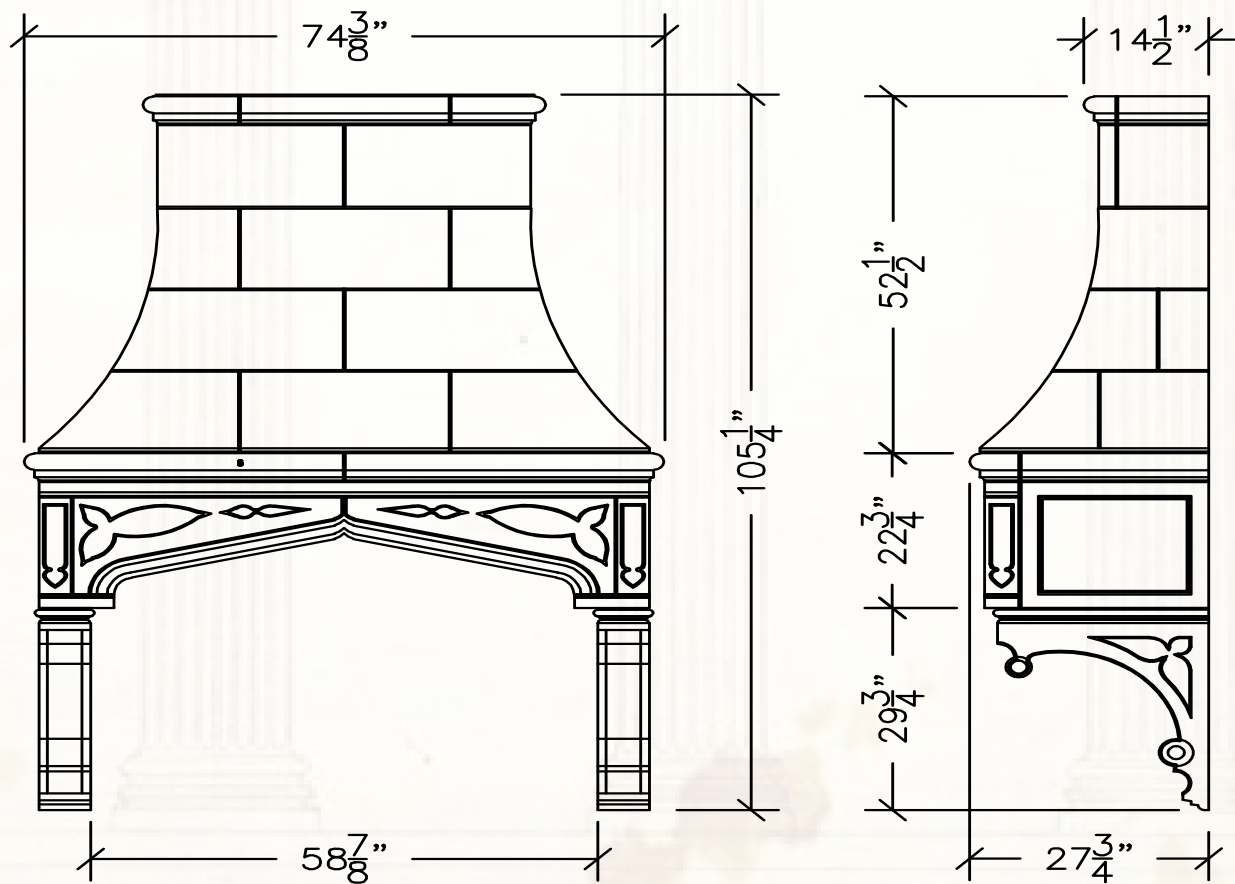

UPPER MANTEL SELECTIONS

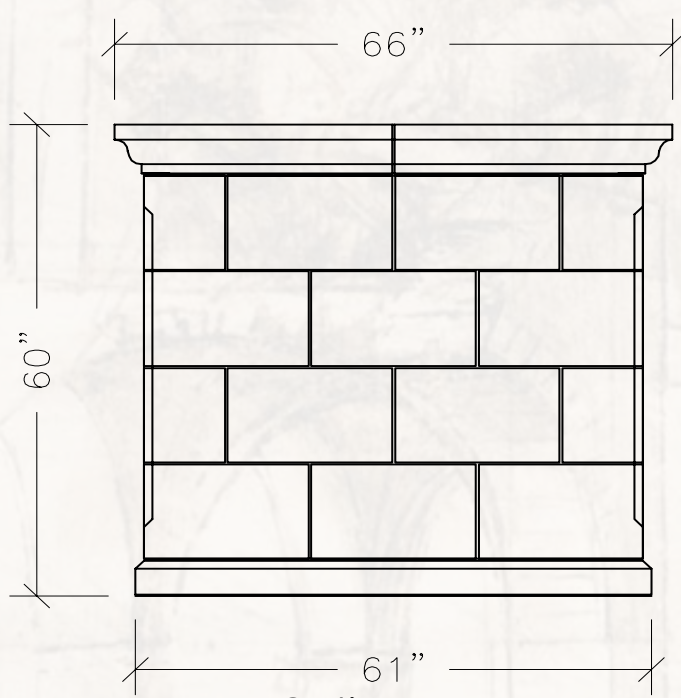

Option I
Stately Mantel

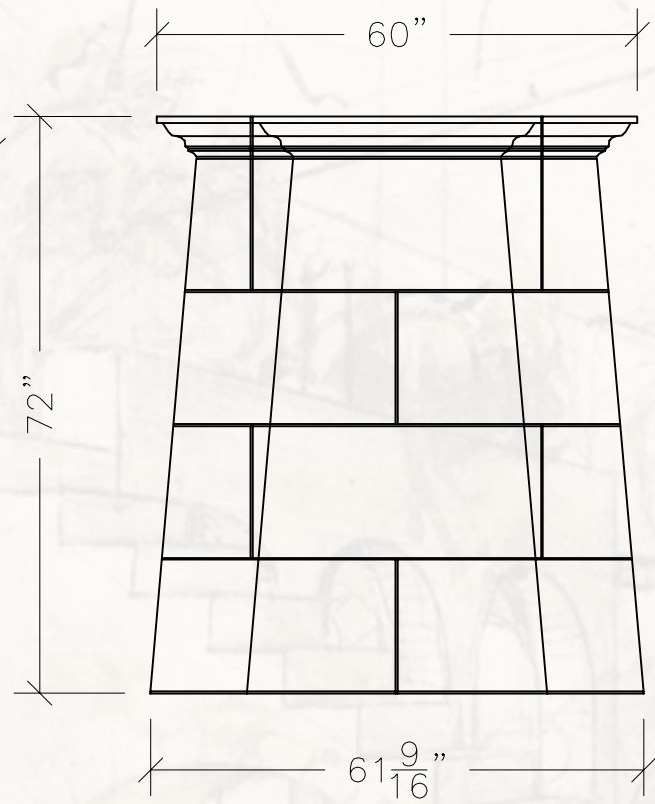

Option II
Double Taper

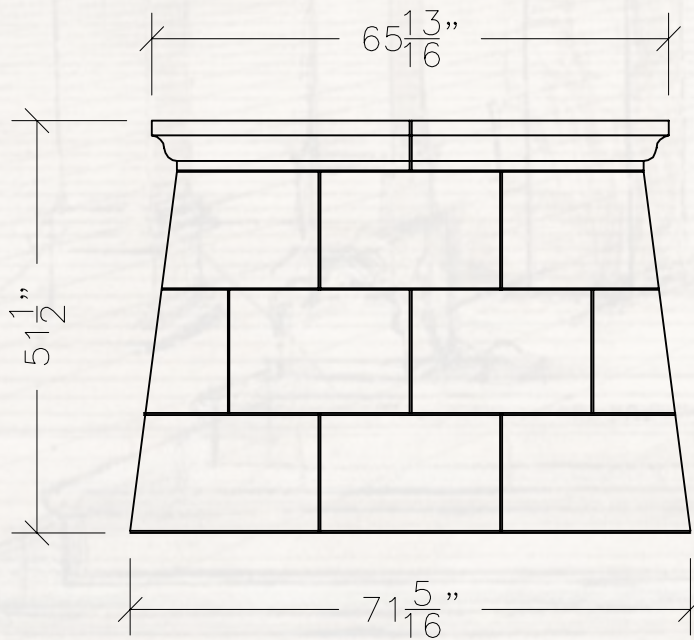

Option III
Single Taper

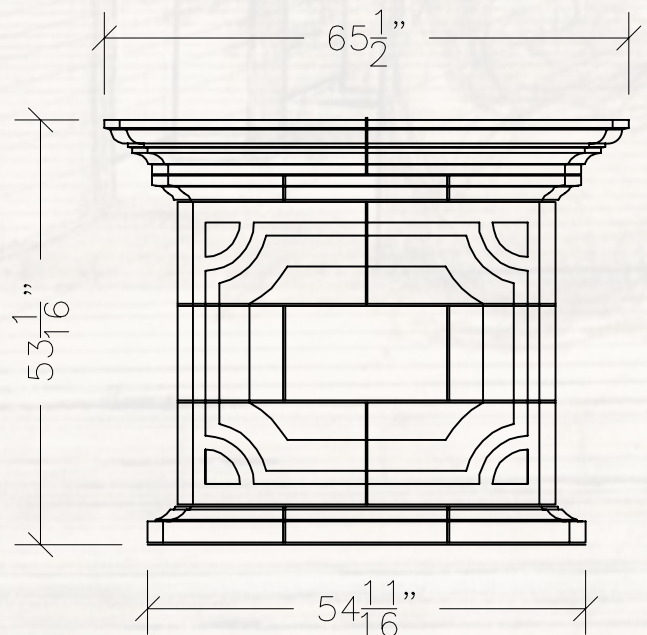

Option IV
Fancy Chamfer

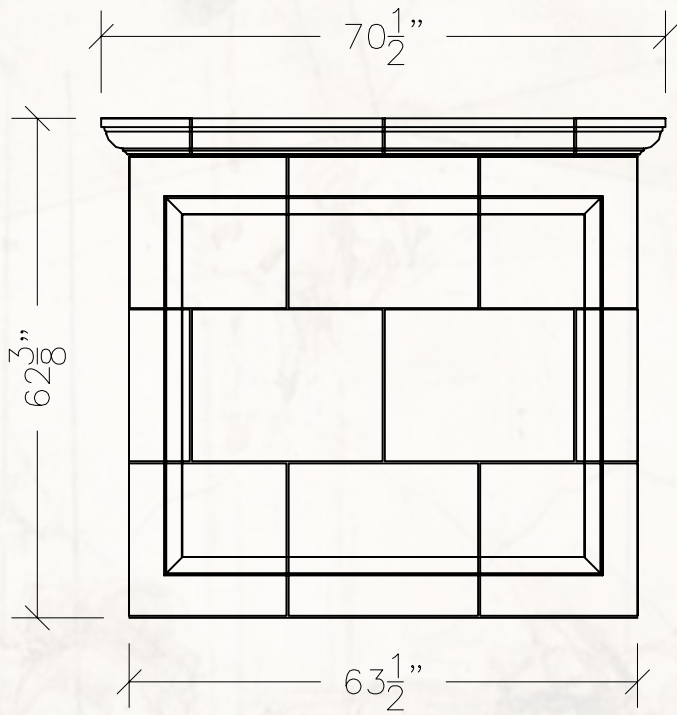

Option V
Chamfer

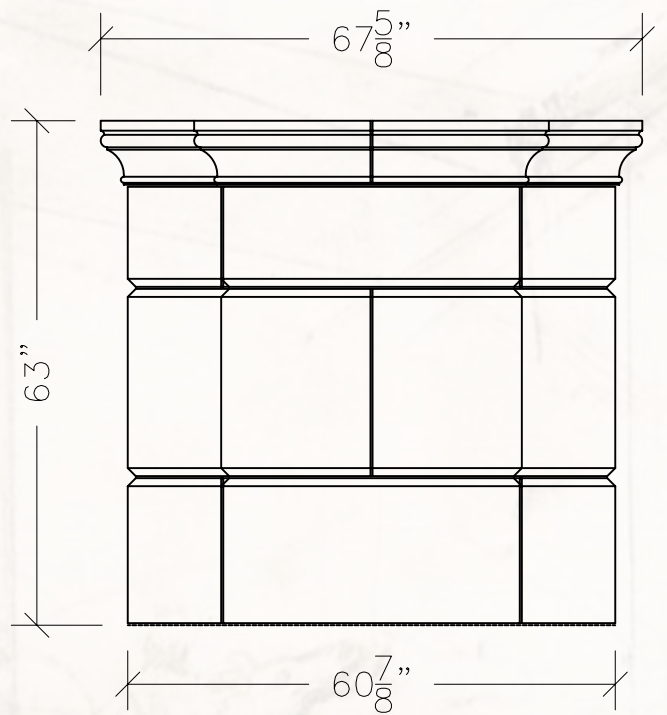

Option VI
Raised Static

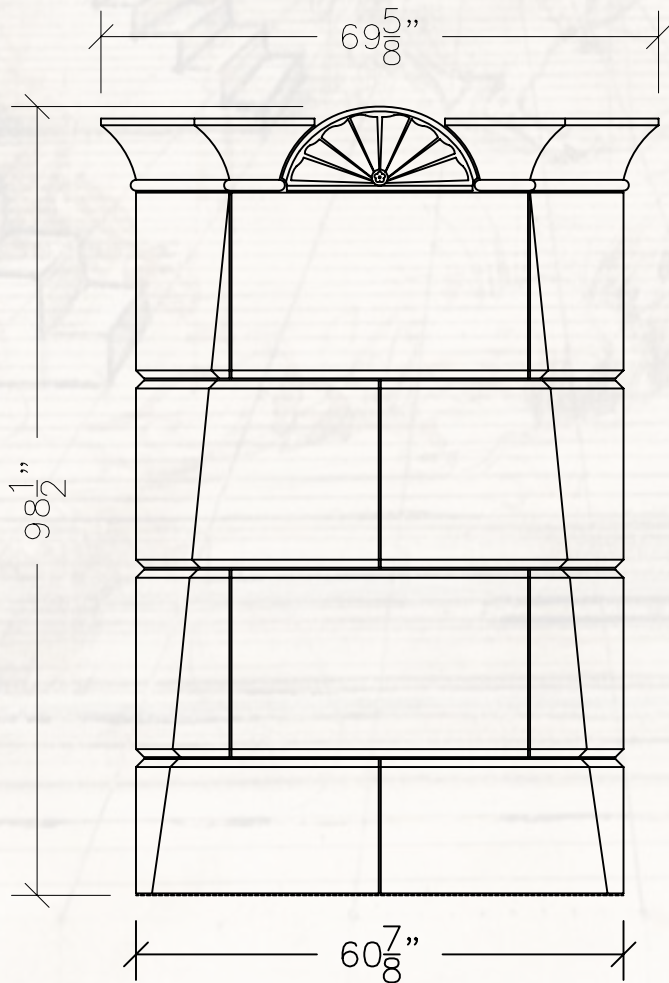

Option VII
Taper Static Medallion

HEARTH OPTIONS

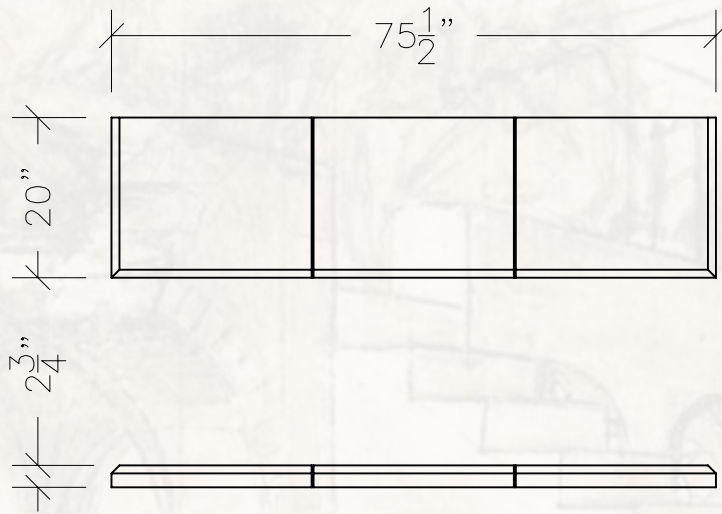

STANDARD HEARTH

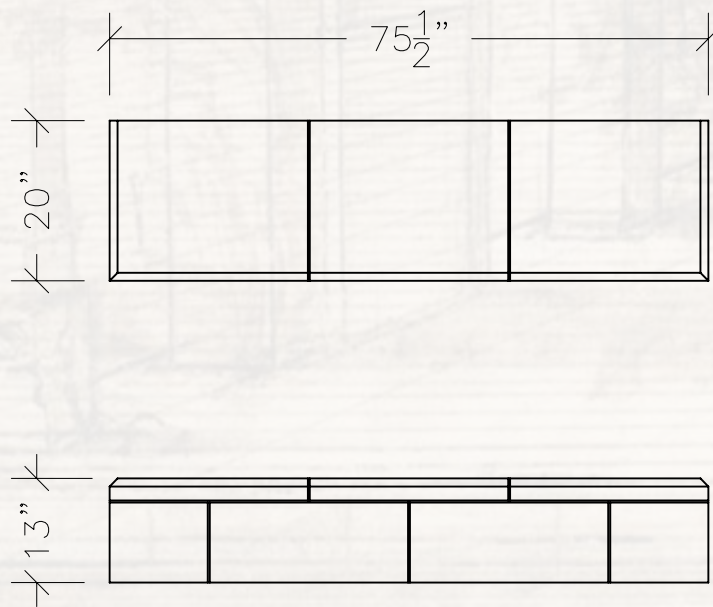

STANDARD RAISED HEARTH

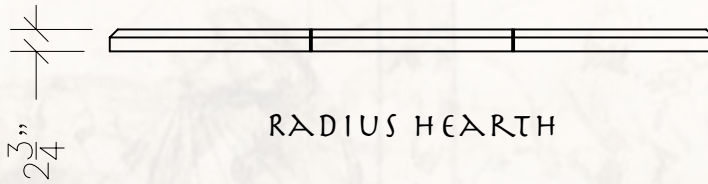
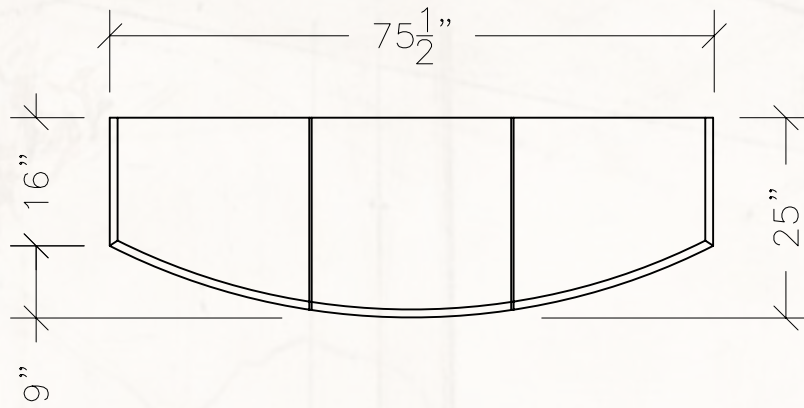

RADIUS HEARTH

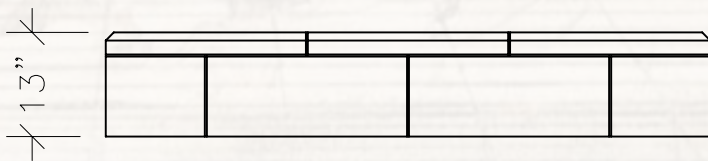
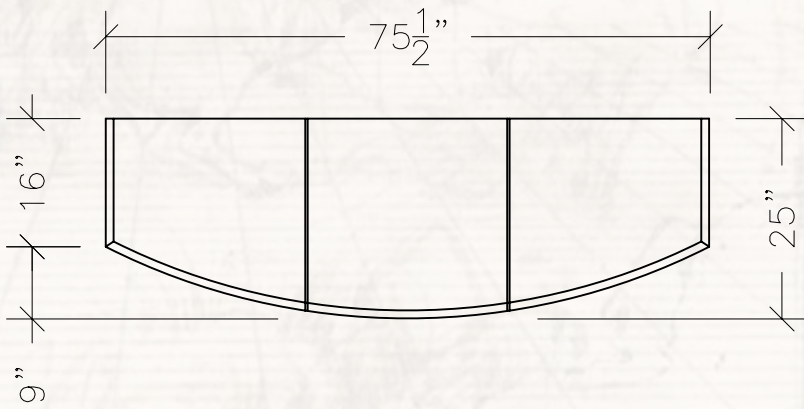

RADIUS RAISED HEARTH

