



FIREPLACE & KITCHEN HOOD CATALOG

Dear friends,

We at Renaissance Cast Stone, are proud to offer our Fireplace book.

We are constantly updating or creating new mantels so keep up with our newly renovated website for current updates to this book

www.renaissancecaststone.com

As always, Renaissance prides itself on our ability to produce the finest dry tamp cast stone in the region, along with the most comprehensive customer care, before and after the sale.

We encourage you to take a look at some of our work available @

Bachels By The Fire

9422 N May Ave

Oklahoma City , OK

405-842-8872

Monticristo Ironworks

5609 NW 4th St, Oklahoma City, OK 73127

(405) 787-0111

As the owner and master mold crafter, I want to thank you for your kind words and continued business with us.

I look forward to building your next fireplace!

Kind regards,

Genaro Arriaga

GM /Master Craftsman

Renaissance Cast Stone

2135 SW 19 th Street,

Oklahoma City, OK 73108

Tel:(405) 514-4780

Fax:(405) 563-9065

About this book:

As with any cast stone company who posts pricing in a catalog, there are some additional costs associated with the price in the book. We will try to prepare you for your budgets as close as we can but keep in mind that some things like freight will always be unpredictable until time of shipment.

About Tracy

Tracy is the figure you see standing next to all the fireplace drawings. She is 5'-7" tall with heels. She is there as a benchmark in terms of scale. To give you an idea as to just how large or small things can be in relation to you and your project.

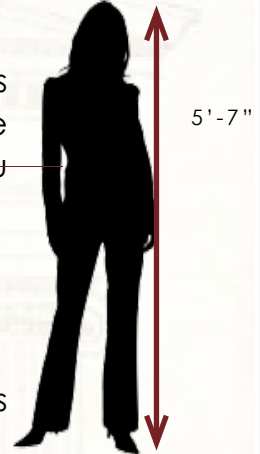

About Additional Costs

Handling is a packaging charge associated with placing the stone on pallets and protecting them in plastic for shipment.

Installation

Is assessed per job and can vary based on job site location and conditions present at time in installation. You can either request installation be done by Renaissance (on fireplaces and Kitchen hoods only), or the mason who is installing your brick / rock package.

Shipping

-As stated above will be estimated at the time of the bid and actualized when the product ships.

Taxes

Local taxes will be assessed to the ship to address and applied at final

Billing.

Deposits of 1/2 of the total estimate will be required to begin the process of creating shop drawings and starting the manufacturing process.

Finish And Color Options

There is no charge for our smooth finish and all three natural colors of white, buff and tan. Olde World, Antique and Coral finished require an additional 25% of materials cost up charge.

Additional color charges are individually based.

Sealing

We recommends sealing your fireplace and have two different sealer options. Please ask your representative for information about sealing and the option of doing it yourself!

SPAGO COLOSI





The Spago Colosi

A massive Mediterranean design standing over 6 feet tall from floor to the top of the mantel. Rope legs, versatile radius or straight filler pieces and the ability to shrink to a smaller product like the picture above, makes for a popular choice.

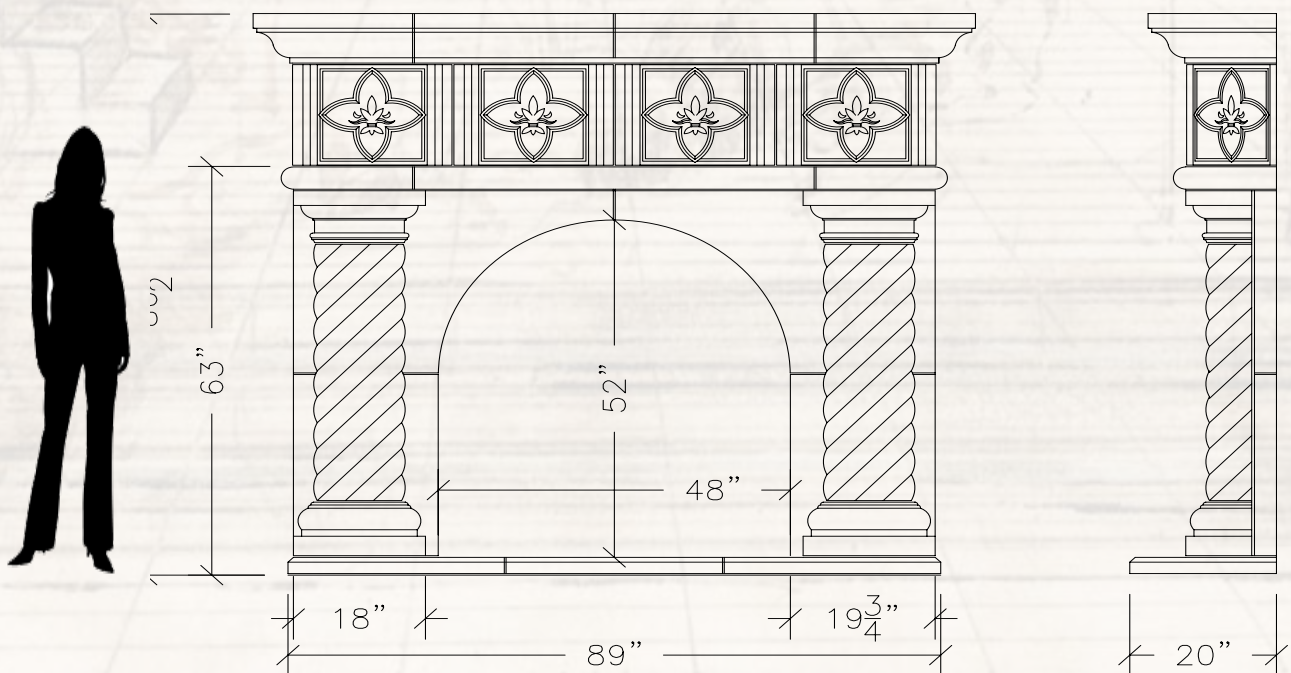

GROTTA





ROCK SALT FINISH

The Grotta

This design has a cave like effect, jutting out from the firebox some 8" or more. Shown here with an upper mantel and a rock salt finish, this fireplace is fashionably diverse as it can set a mood in a contemporary, Cape or French Country atmosphere. Available in a 36" or 42" firebox designs

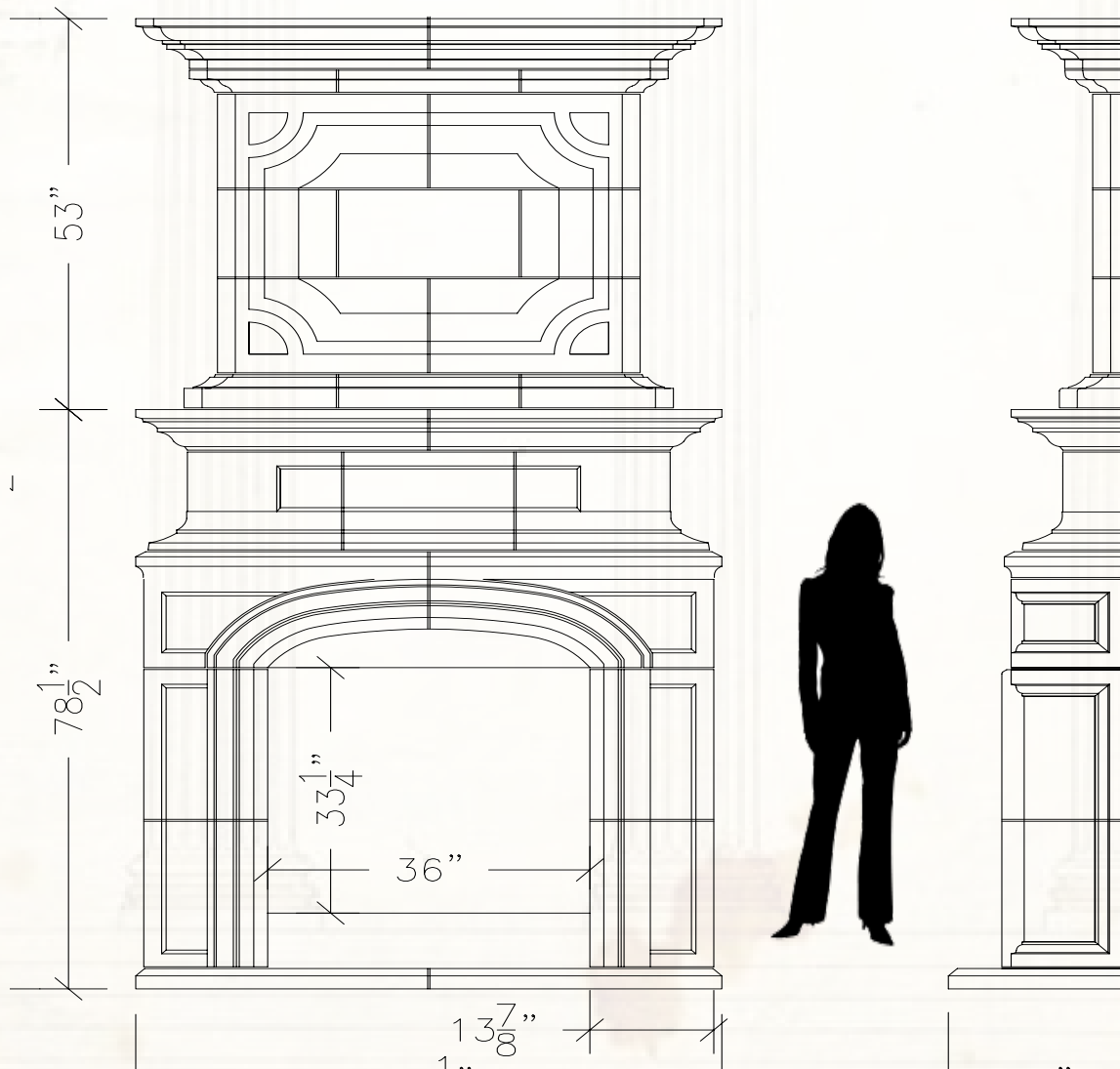

CORVARE



OLDE WORLD FINISH



The Corvare

Marries simplistic lines with complex curves. An impressive girth on the mantel allows for plenty of space for decoration! Shown above with our new

“Olde World” finish.

Available in a 36” or 42” firebox designs.

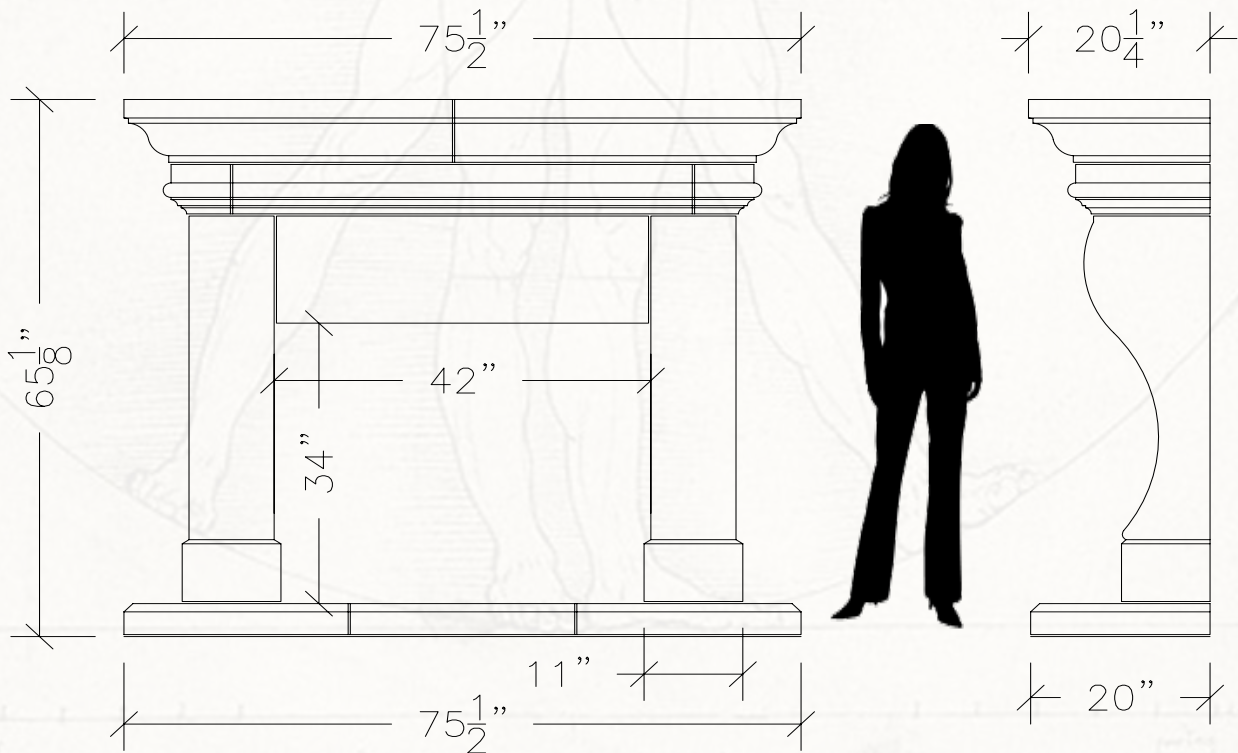

SOSTENERE





The Sostenera

Corinthian column style legs and attention to the smallest detail makes the Sostenera capture the eye and the imagination! It will take your guests more than one glance to appreciate the Exquisite design.

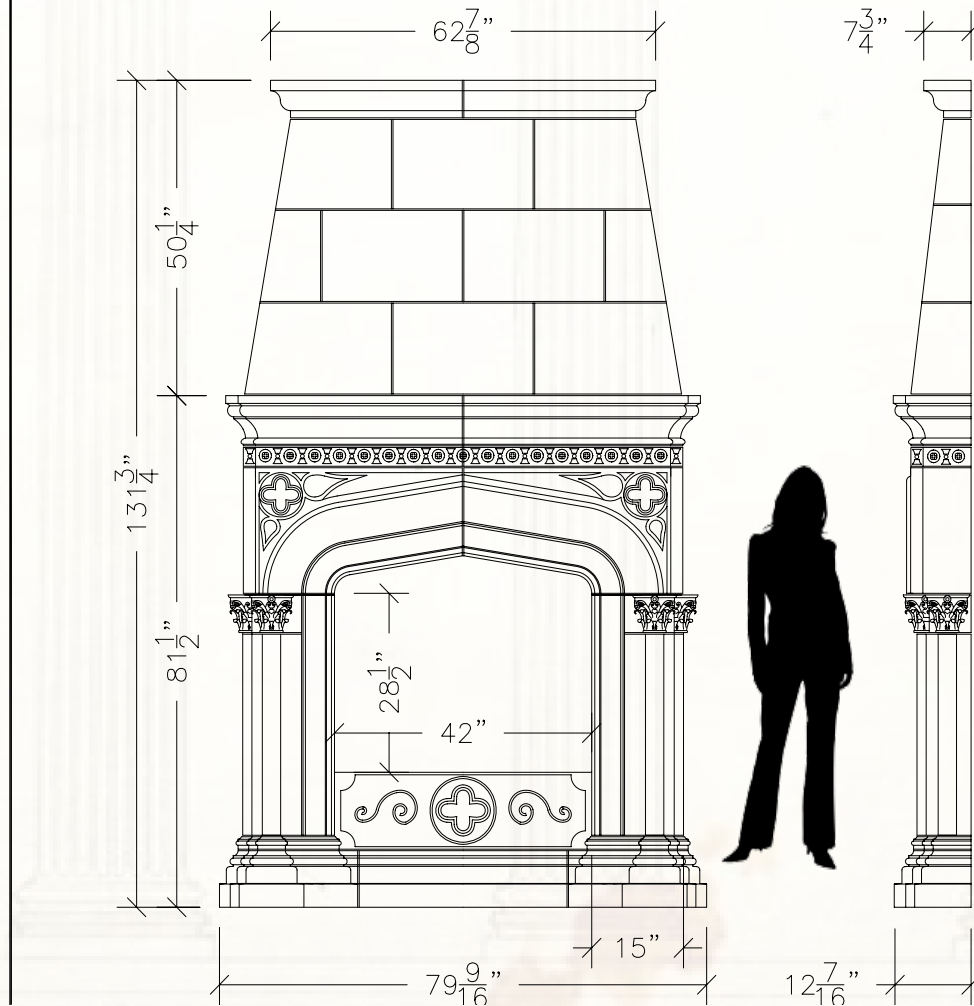

A R C O





The Arco

With clean lines and arches, this strong mantel, wide leg and foot lends to a deceptively massive appearance yet does not crowd the room.

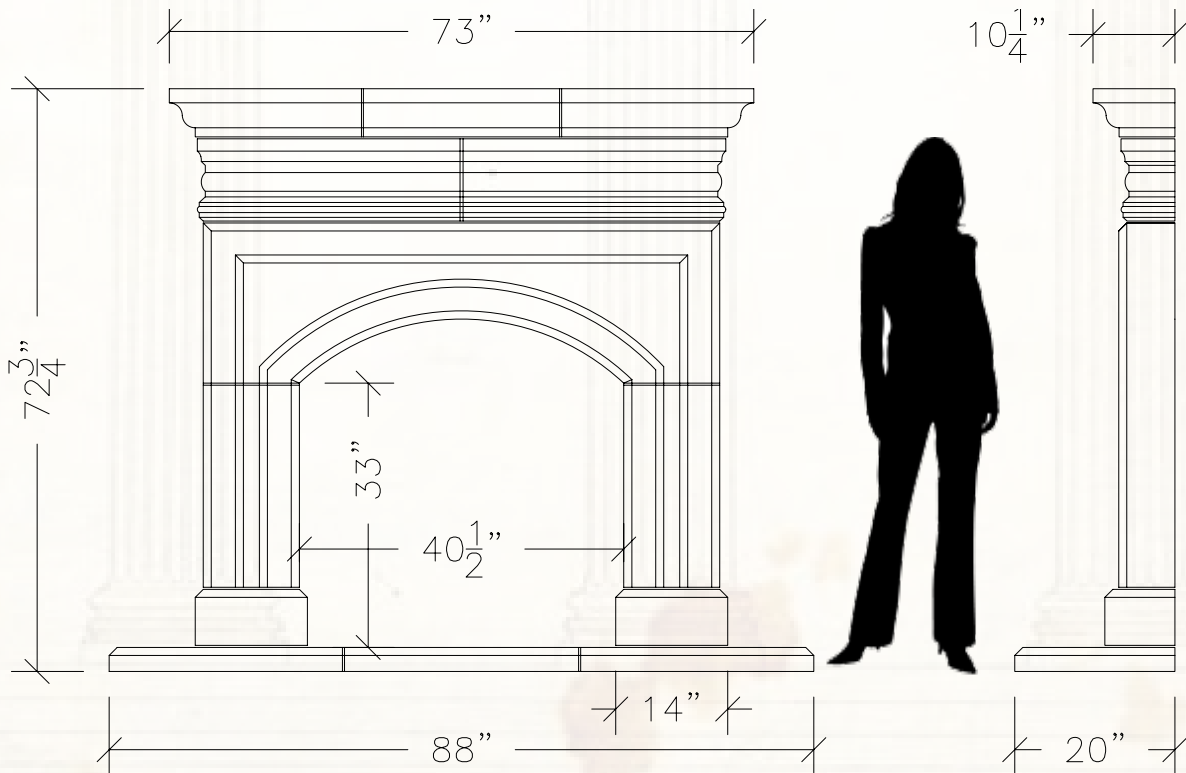

BELLA LEE





The Bella Lee

With columns for legs and a block style radius mantel, this offering carries a southern style charm into your room.

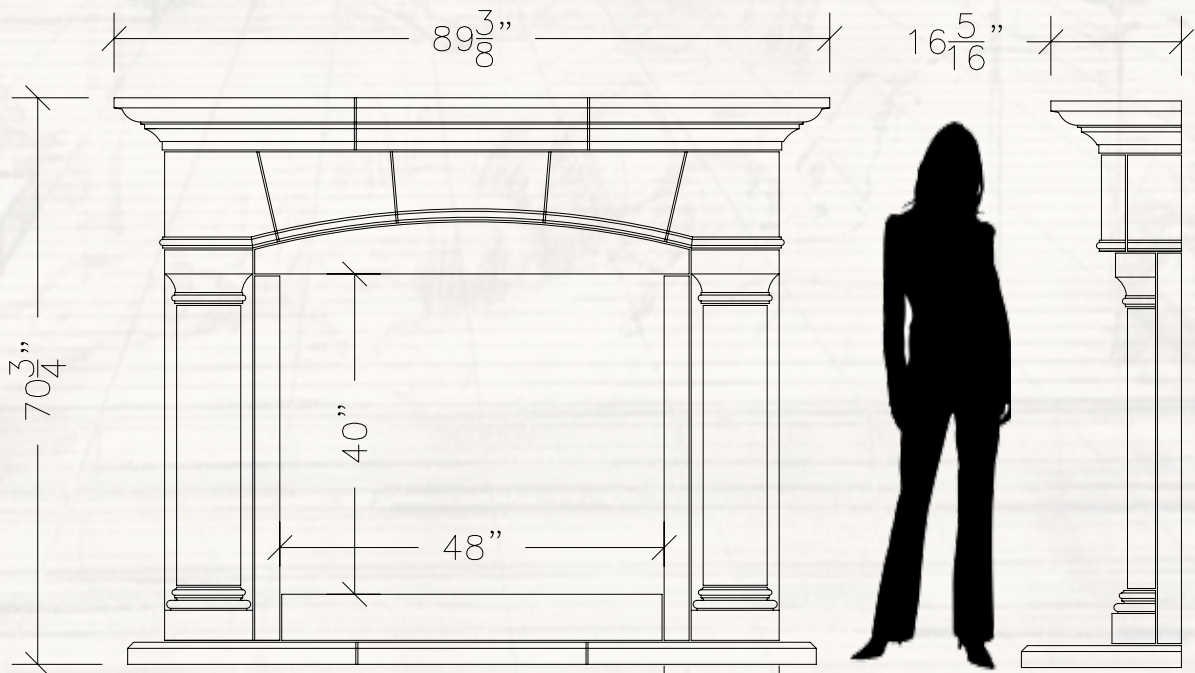

BRISBANE



Rock Salt Finish
Raised Hearth



The Brisbane

The details and overall size of this marvelous mantel make it a standout in the Renaissance line. Each time you study what seems to be a fairly ordinary design, your eyes discover another subtle complexity.

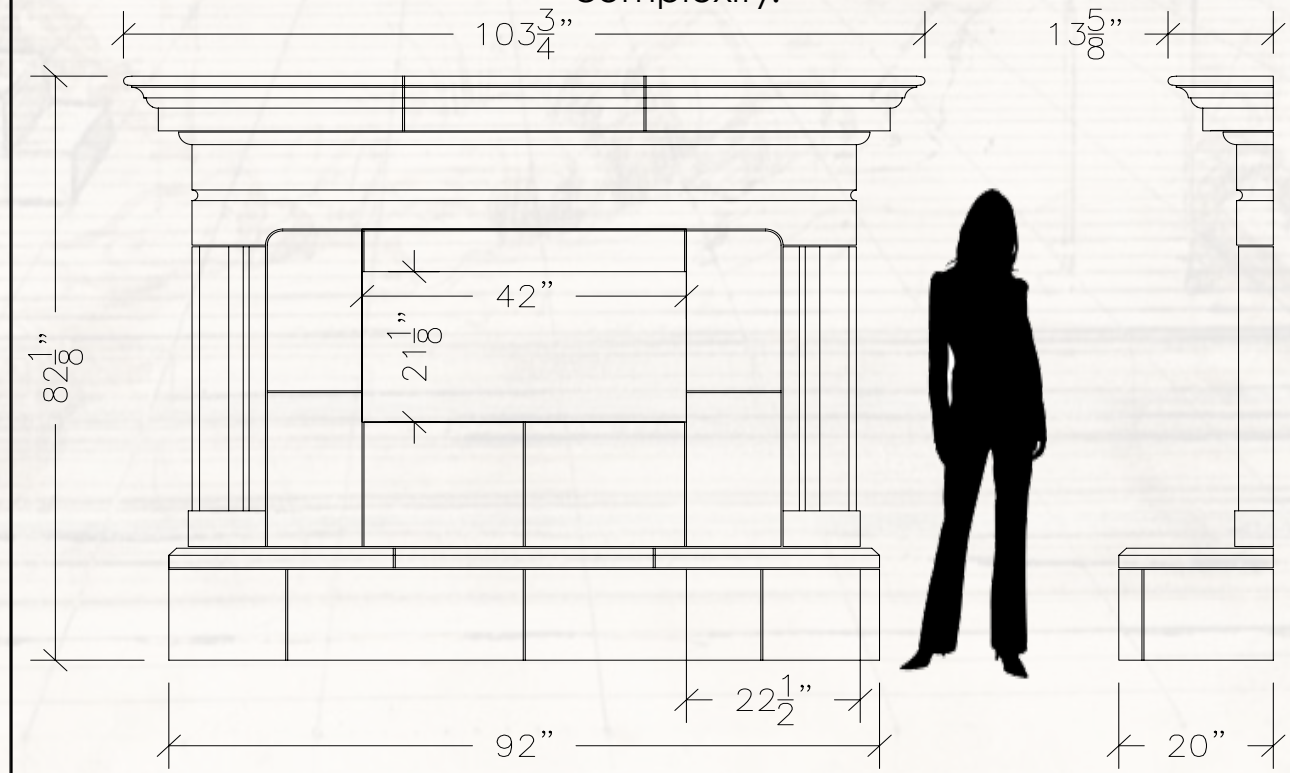

LOMBARDY





The Lombardy

The most ornate mantel in the Renaissance line-up also boasts great mass. This unmistakable statement demands the attention of your guests and always gets you rave reviews if placed in the right room.

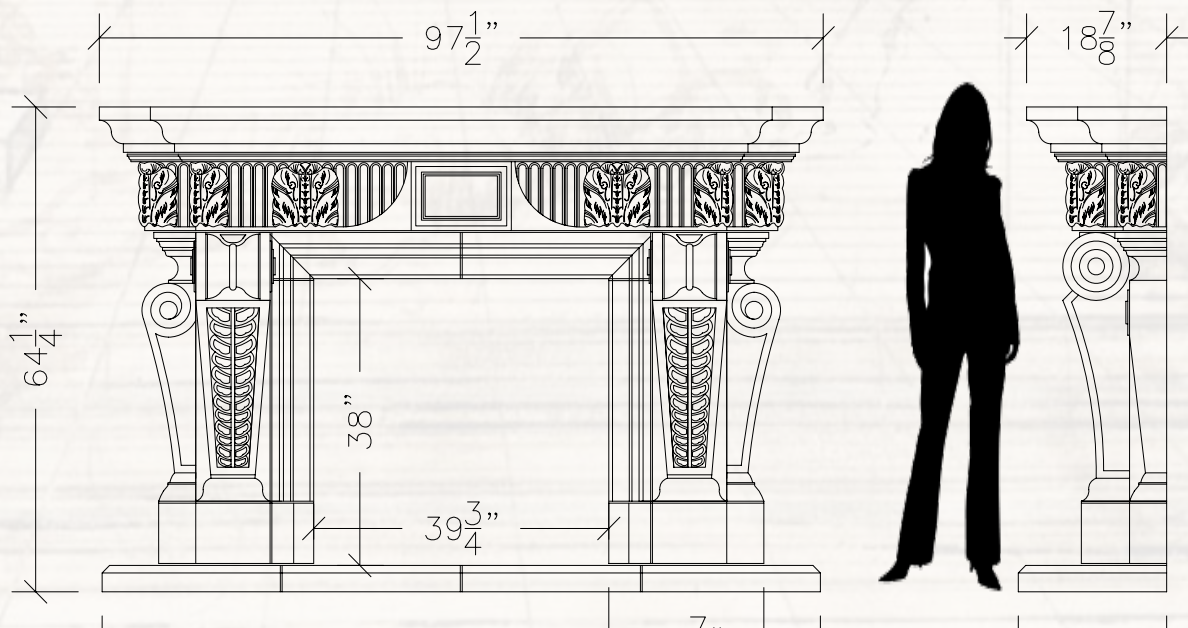

OXFORD





The Oxford

Deep, defined patterns around the arches and legs, interrupted by either a scroll or ornate corbel, the Oxford is defined by the great "City of Dreaming Spires" for the early advances in architecture.

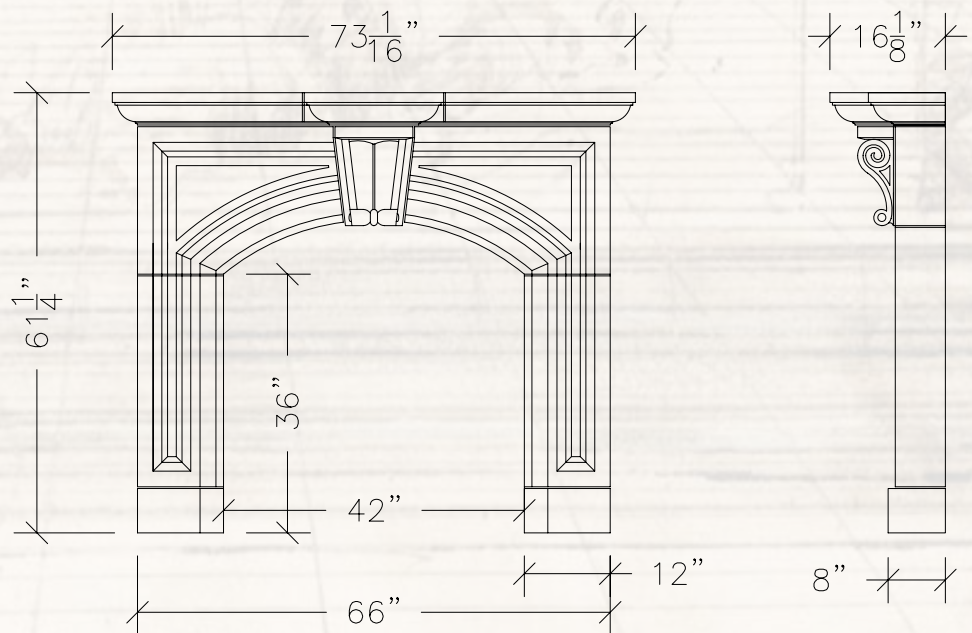

PRIMA DONNA

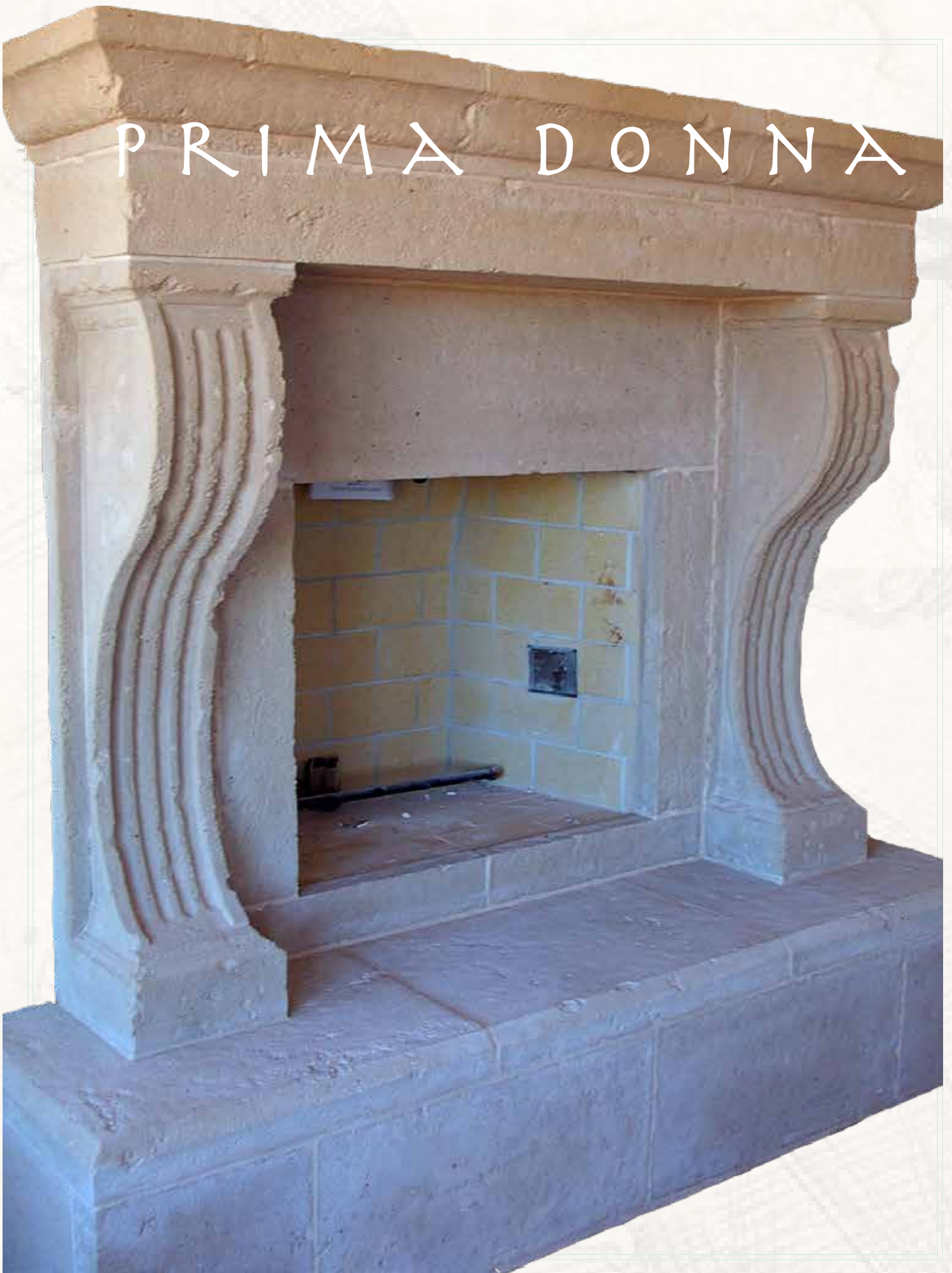



The Prima Donna

Like the name evokes, this petite mantel shouts for attention. Fluted, subtle curved legs, under a simple mantel and crown.

Shown left with our "Olde World" Finish.

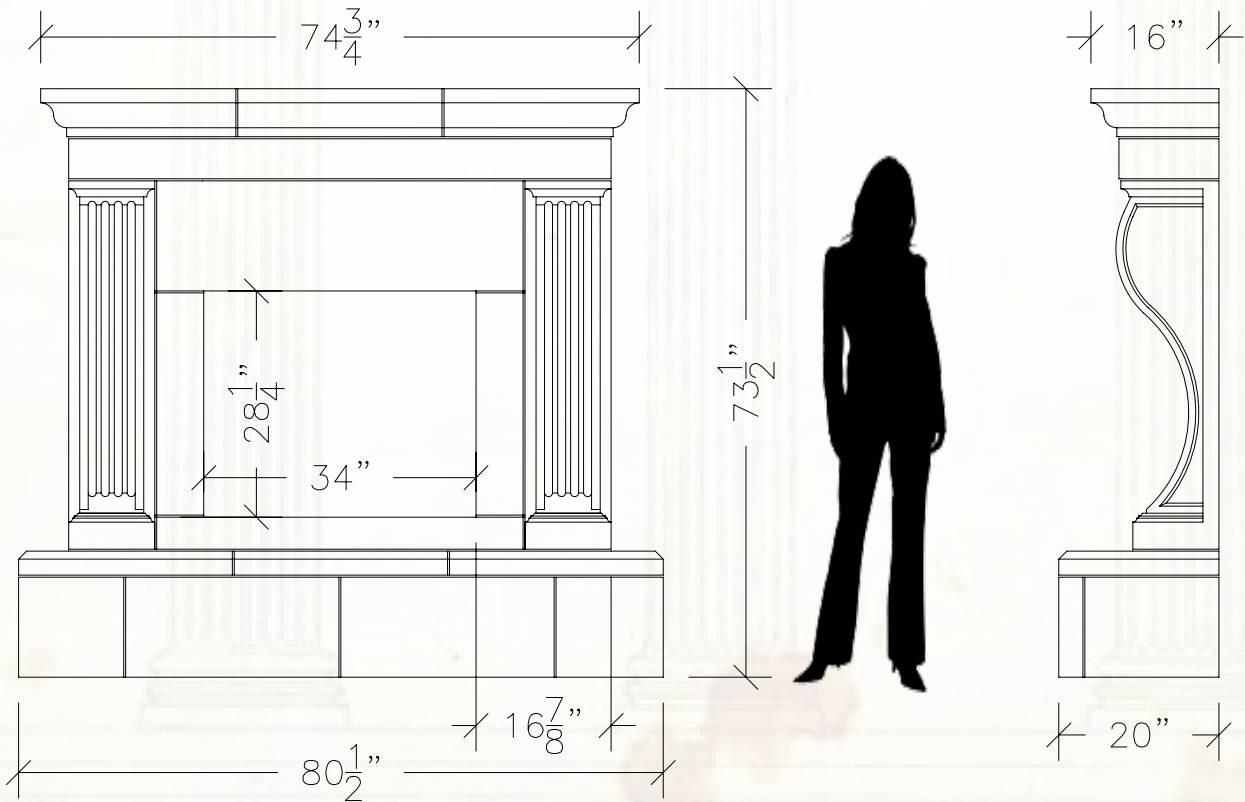

SHELBY



Shown with upper mantel to 13-4



The Shelby

With the mantel topping out at over 6' tall, The Shelby is one of our largest and most complex. Rope column legs, defined box complexity and sheer mass. Choice of 2 different insert panel designs. This one can fill a large space with an impressive wonderment.

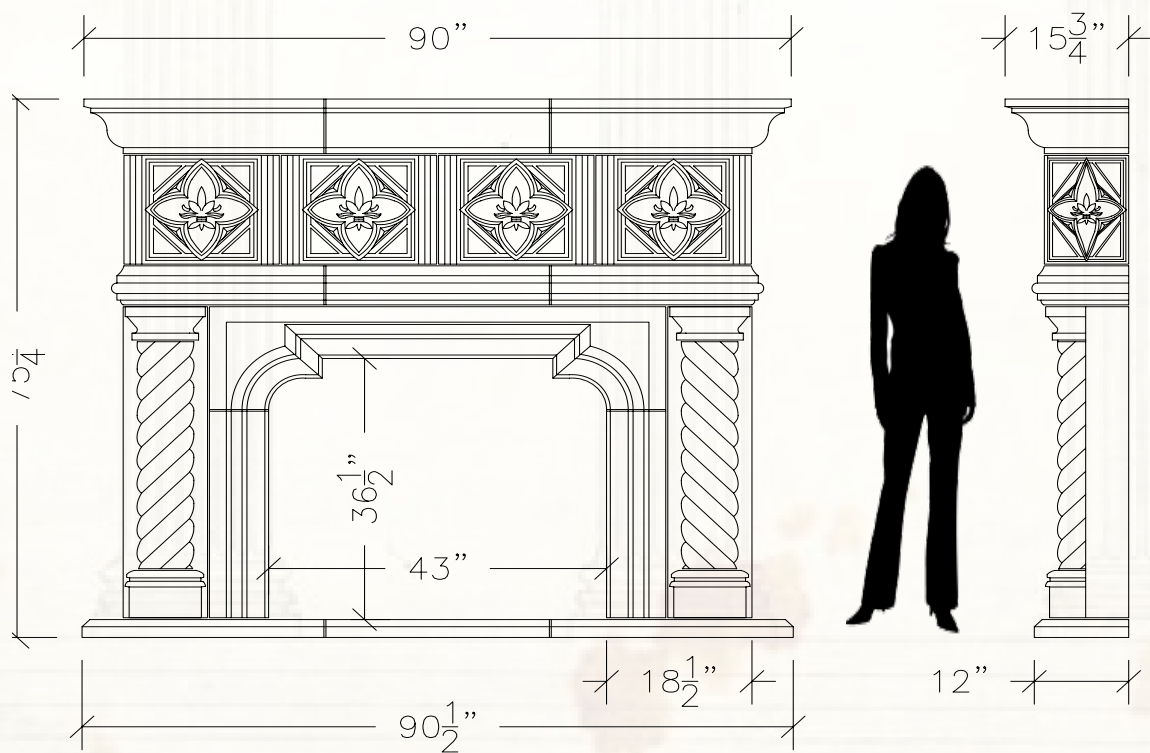

TERRITORY





The Territory

Seemingly understated at first glance. Upon further study, The Territory reveals it's hidden charm of clean lines and simple subtleness.

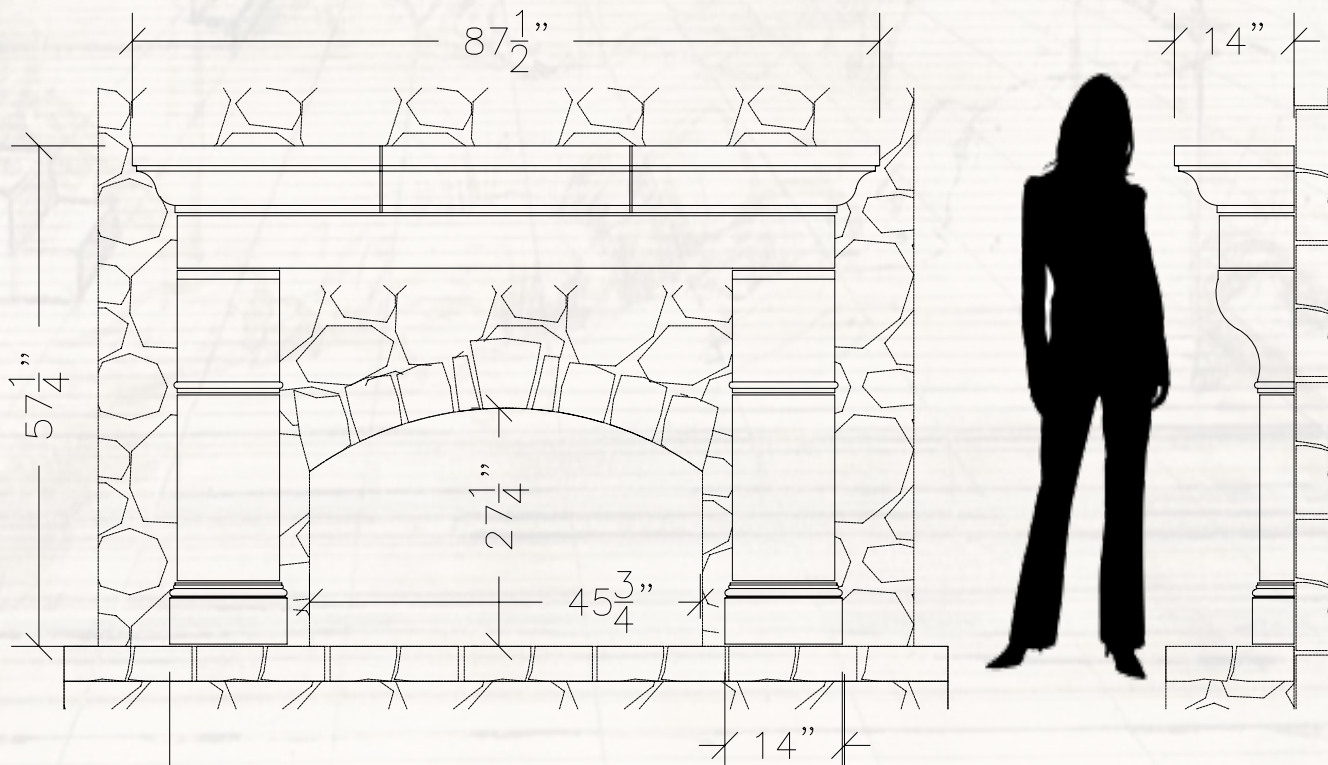

VERSAILLES





The Versailles

Inspired by the birthplace of the Louis XIV Monarchy, a classic Louis with refined, elegant craftsmanship.

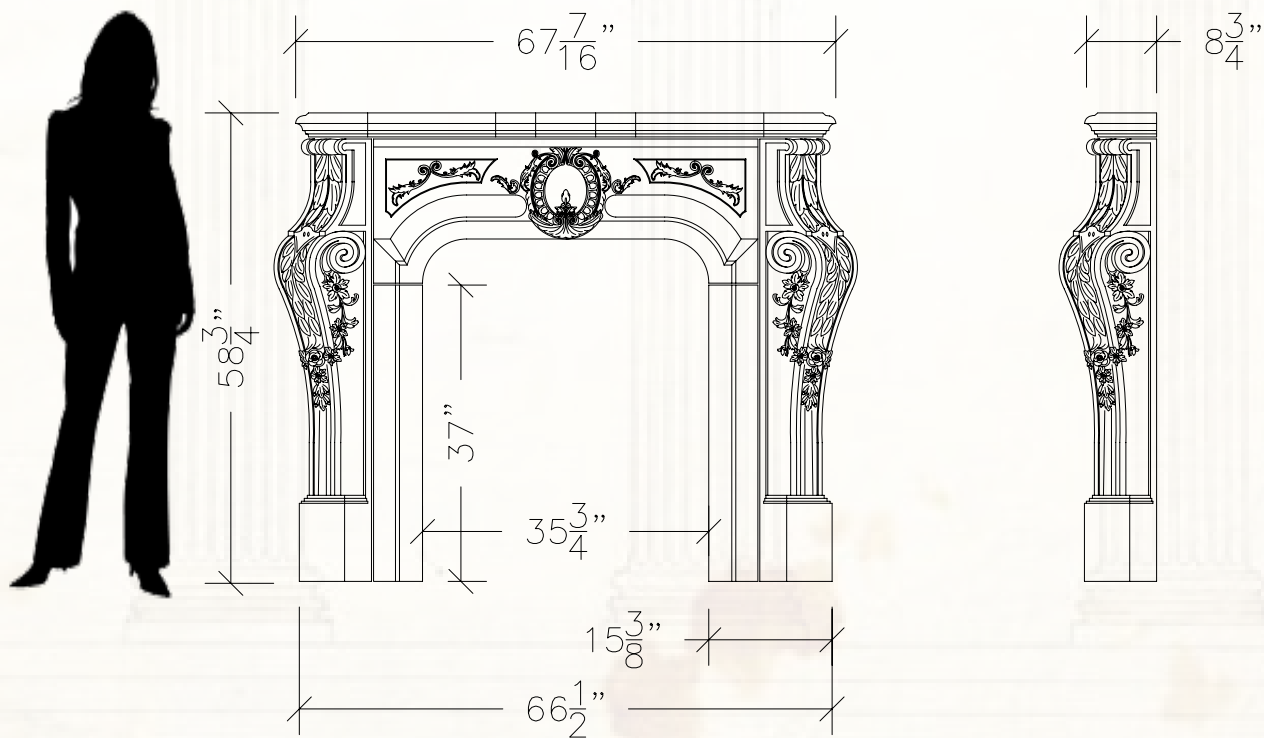

R O C C O





The Rococo

“Very Ornate” in any country, the delicate tapestry of design in the Rococo is easy to fall for. A fitting mantel for a simple room to add complexity and detail.

(Pictured above in the Rococo Classic design with a straightened header in place of the curve pictured left)

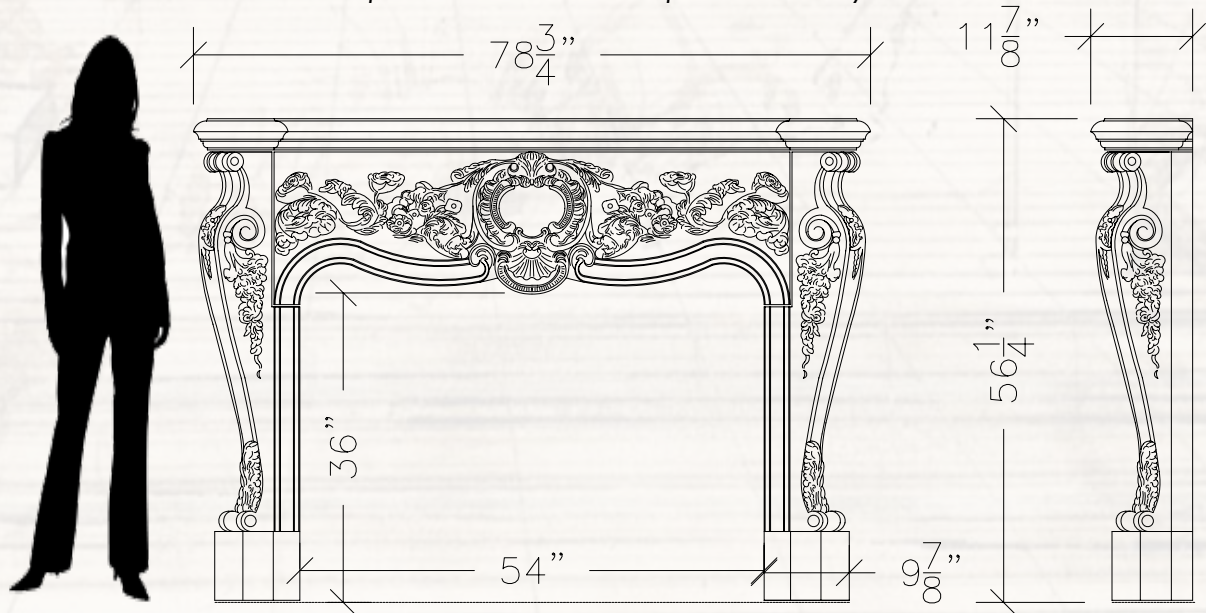

SPICATO AL PIETRE





Spigato Al Pietre

Quite literally,
"Herringbone in the
rock"

This amazing
tandem beauty can
be placed without
it's rock counterpart,

but was designed
to work with other
types of stone or
masonry, which
gives it's intricate
designs a canvas on
which to shine.

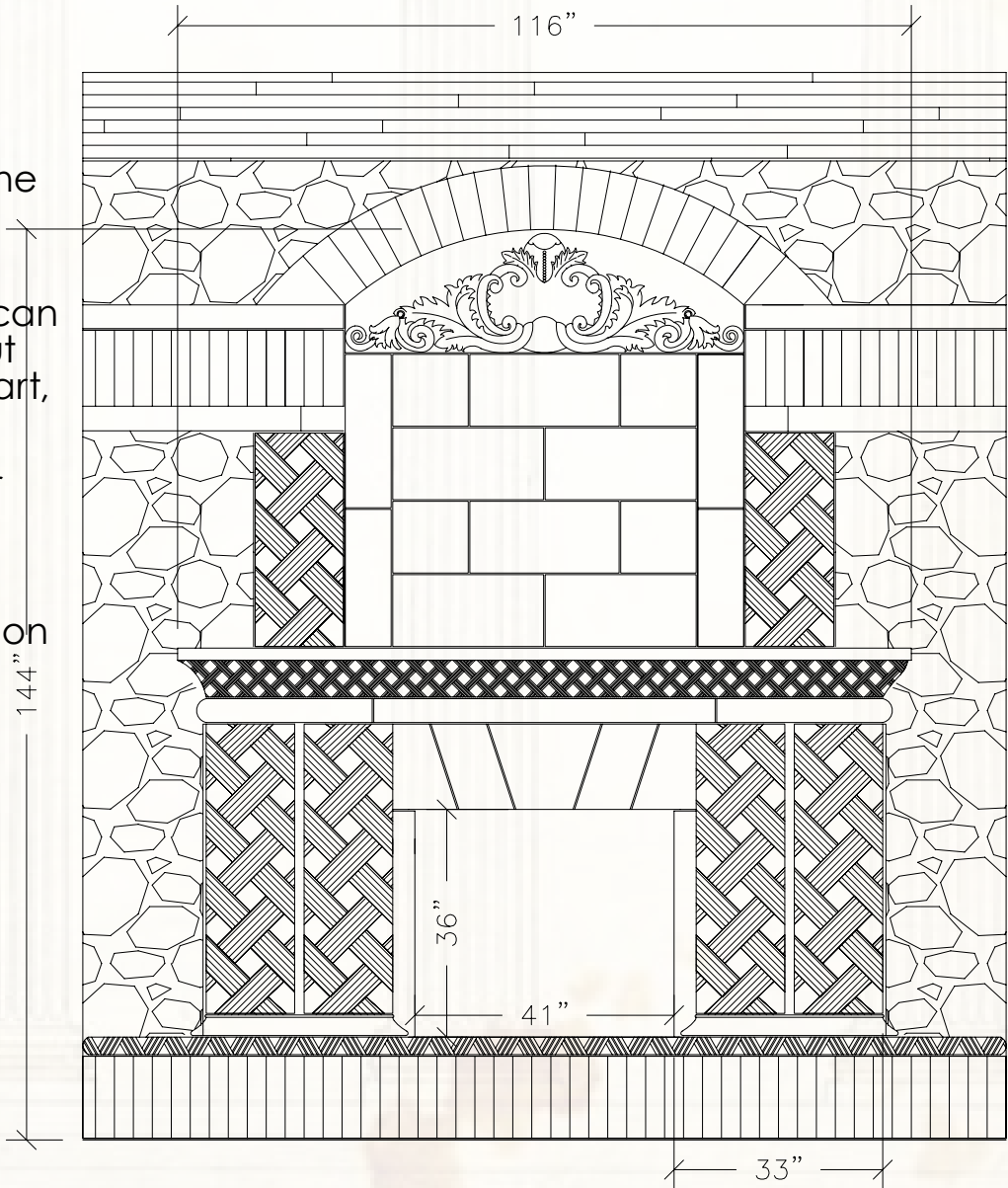

WISIAN





The Wisian

First in our series of the Ode to Italy, the bullnose banding makes a ledge that defines the lines between the legs and mantel like no other.

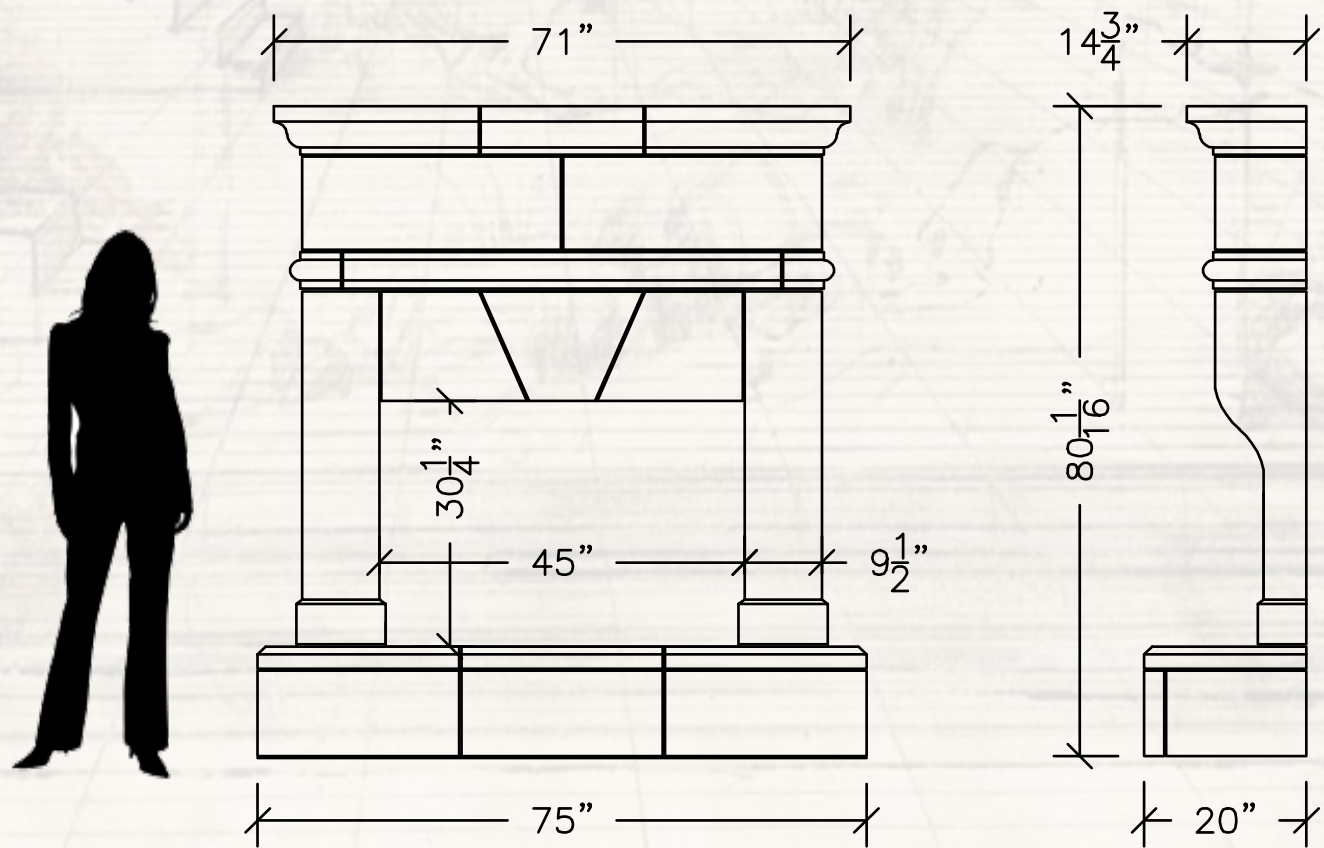

GRABEL





The Grabel

The Grabel, second in our Ode to Italy series is shown acid stained. Yet another in a series of simplistic, yet strong statements. Classic lines are hard to argue, as the presence of this piece will not be overlooked.

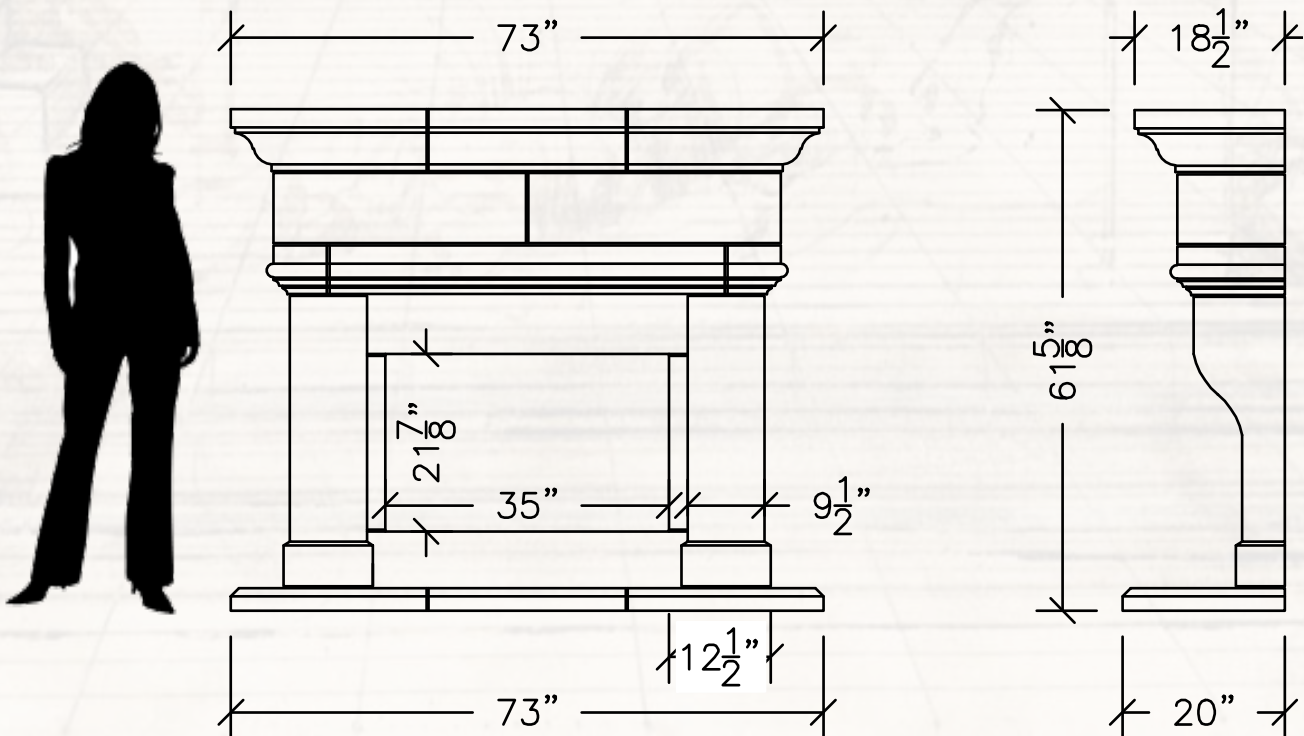

TUSCANY





The Tuscany

Third in our series, popular for its smooth appearance. Old style charm is written all over this mantel. A very versatile product capable of spanning many different decors.

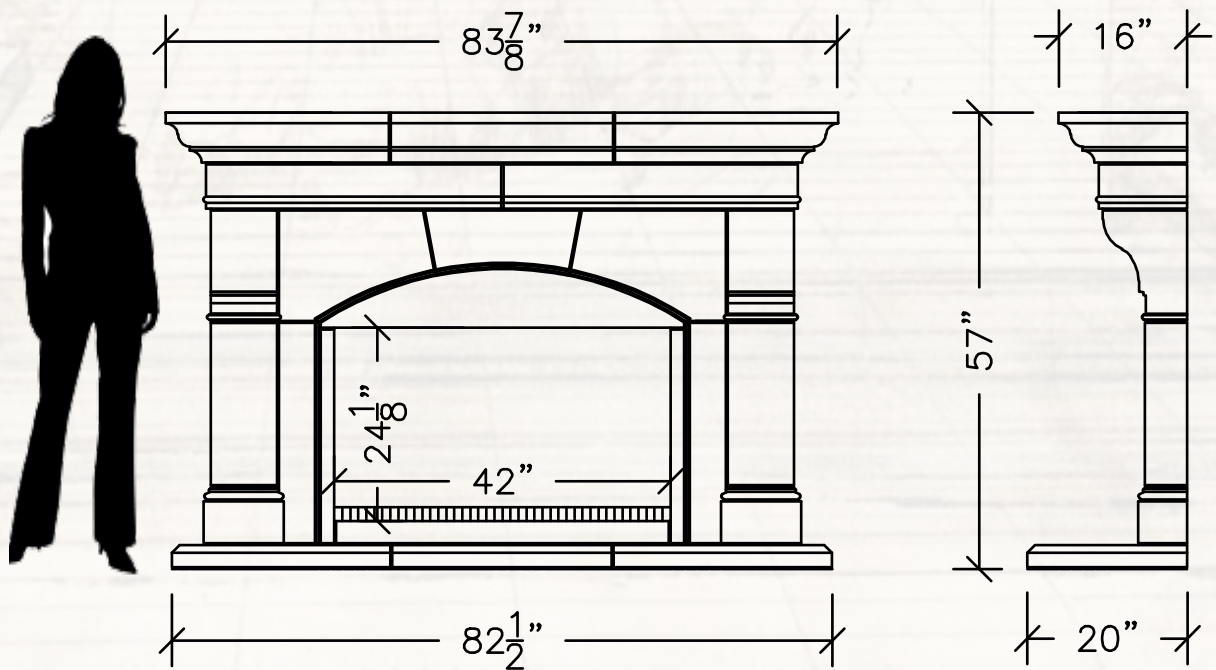

WALDORF

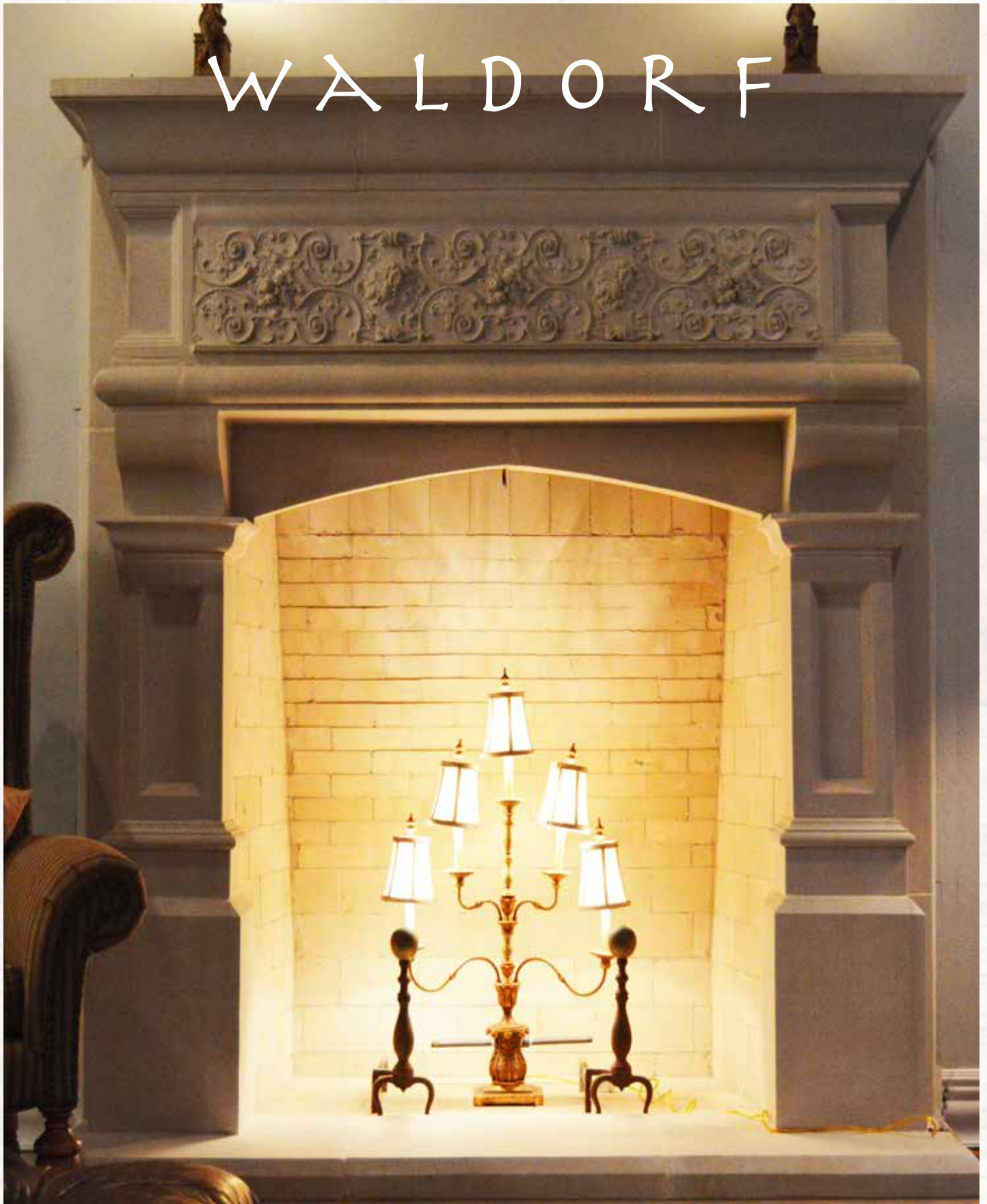



The Waldorf

A Rudolph Steiner inspired mantel that has learned from other pieces to have it's shapes and intricacies creatively carved out to form it's own identity.

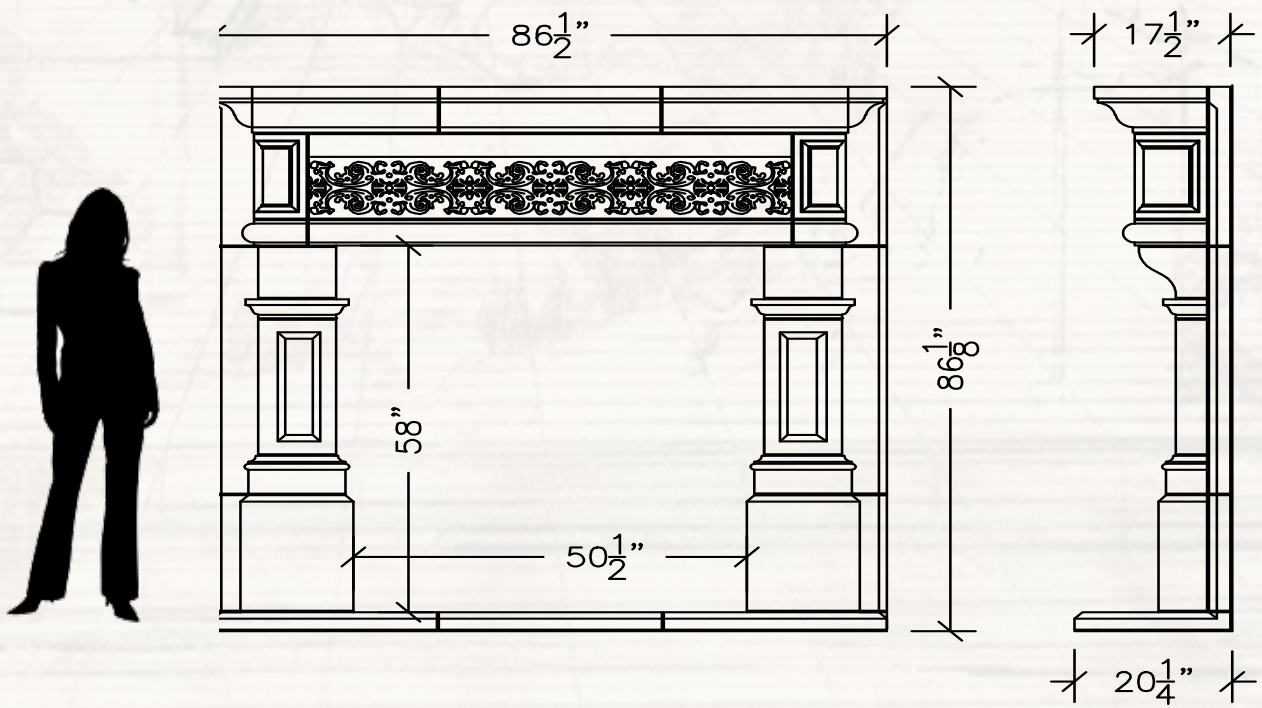

LEONE D RAFFINATO





Lione d' Raffinato

Our "refined Lion" is named after its lion-like paws at the base of the legs.

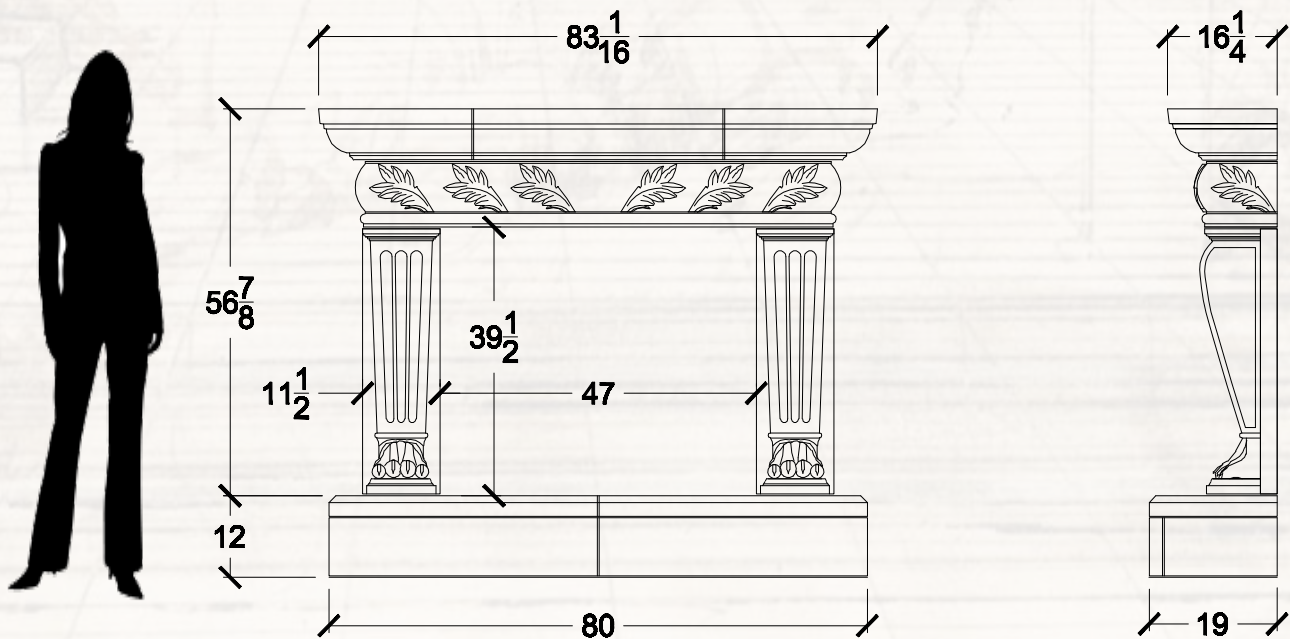

P R E S T I T O





The Prestito

To “borrow from”, The Prestito borrows ideas of designs from other designs combined to make a statement all it's own! Columns for legs, the radius filler and the sharp mantel adds clean and precise to any room.

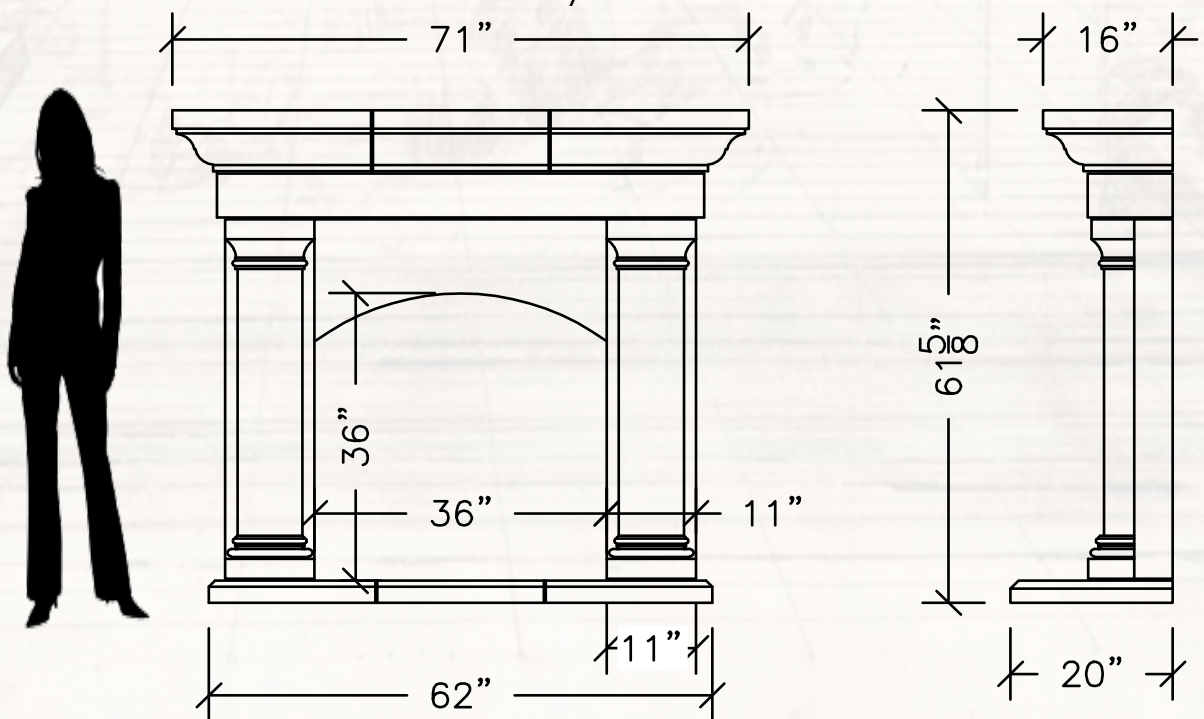

ALORA





The Alora

The first design in a series of five affordable yet beautiful cast stone fireplace mantels.

The "Builder Series" offers elegantly simplistic lines and clean designs that range from contemporary to traditional. Keep an eye out for the next four.

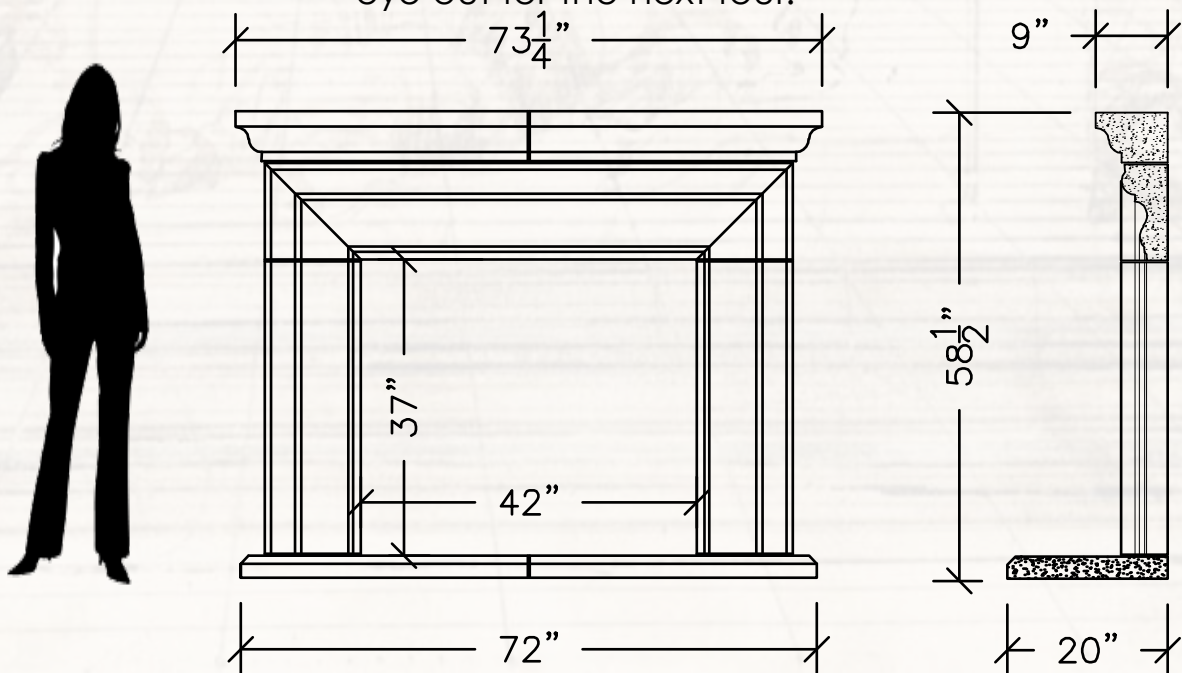

SOPRESA





The Sopresa

Our little 'Surprise' mantel that can fit anywhere, ideal for remodels or places with little support like upstairs fireboxes. Additional corbel designs and the ability to change flat panel configurations make this the most flexible cast mantel out there.

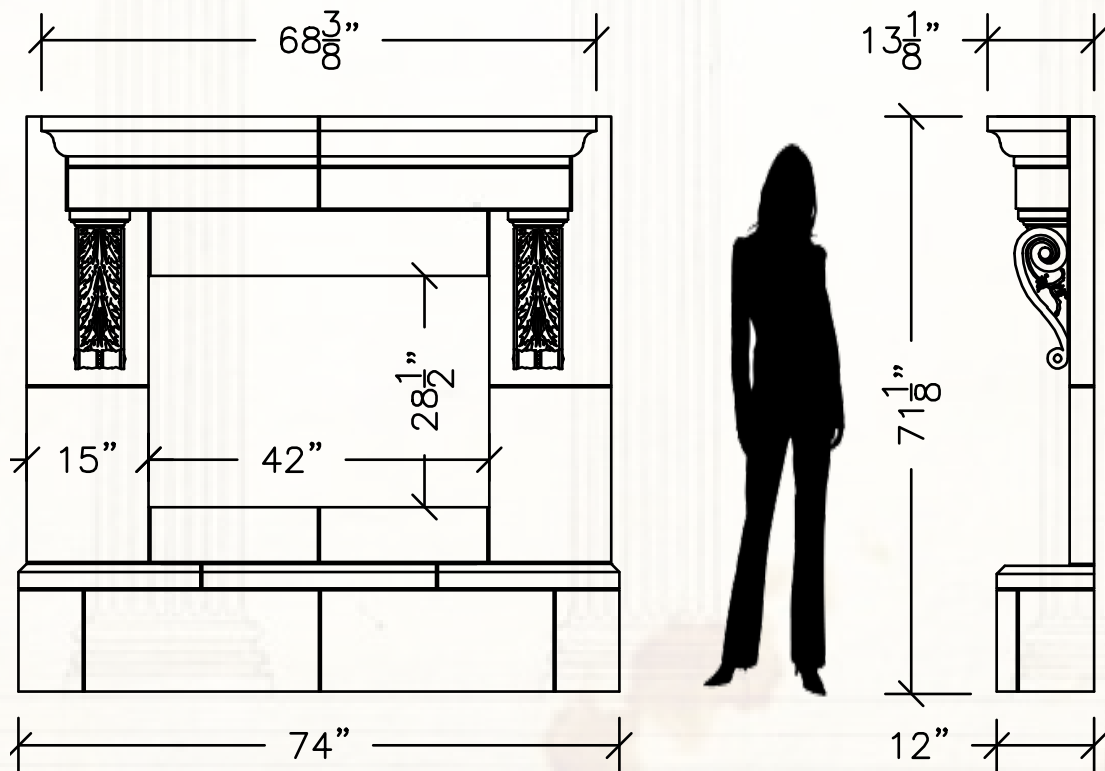

FLATUO TORO





Flauto Toro

The name refers to the fluted legs under the Bullnose shapes on this clean design.
A quiet punctuating statement indeed.

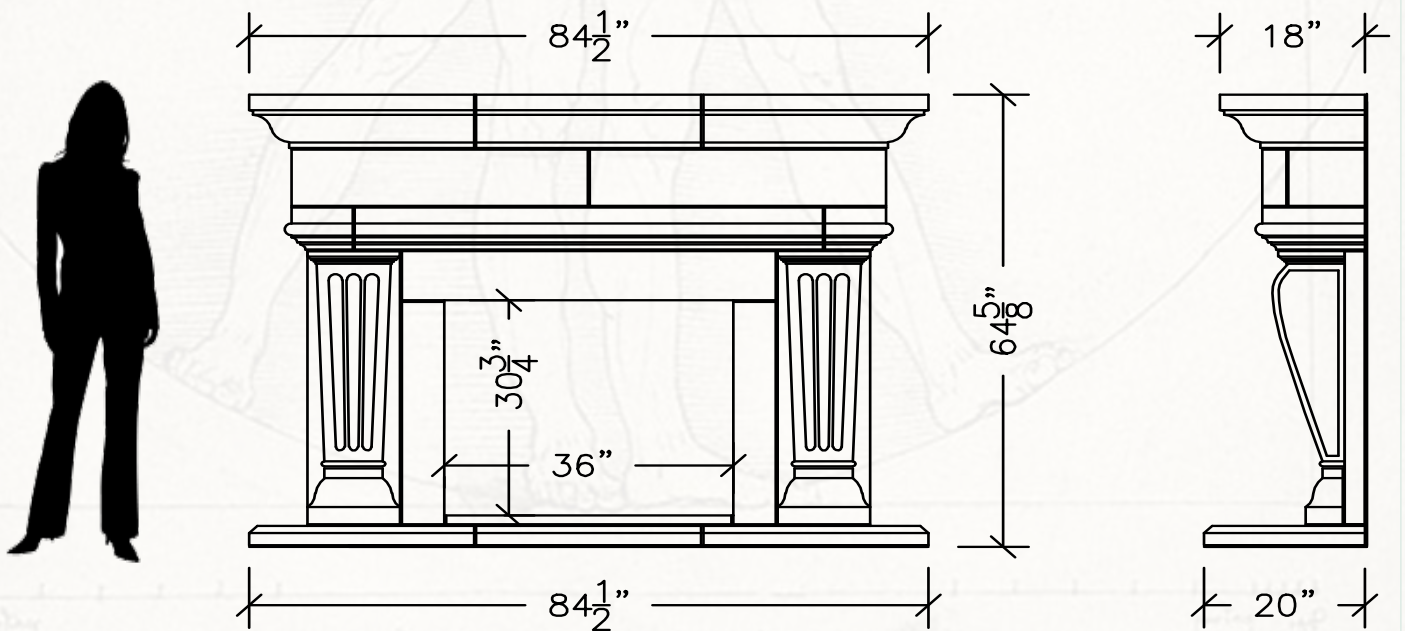



The Angolo

Deep beveled sides and mantels highlight towards the firebox, the fire and the reason you have a fireplace to begin with. Clean and sleek.

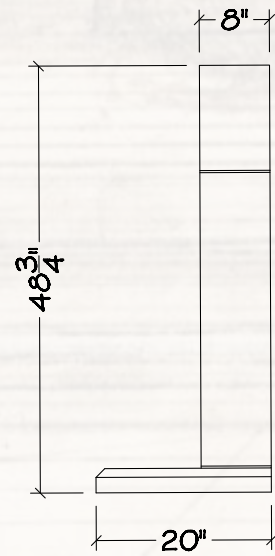
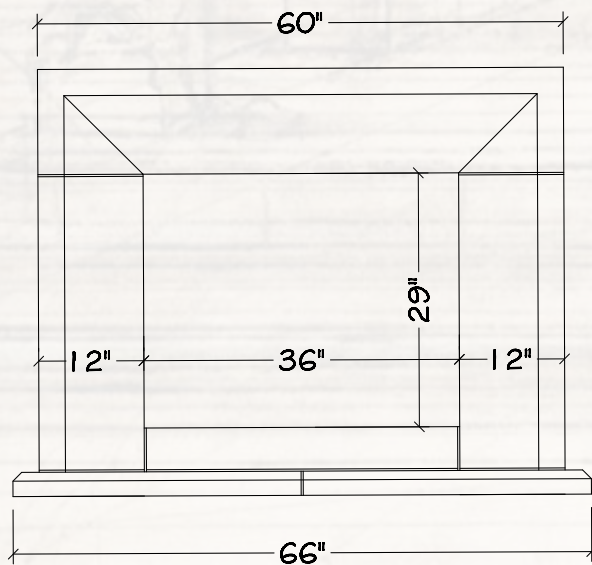

SCINTILLE



The Scintille

A less is more approach to get "sparks" to fly and eyes to dazzle upon this beautiful, delicate design.

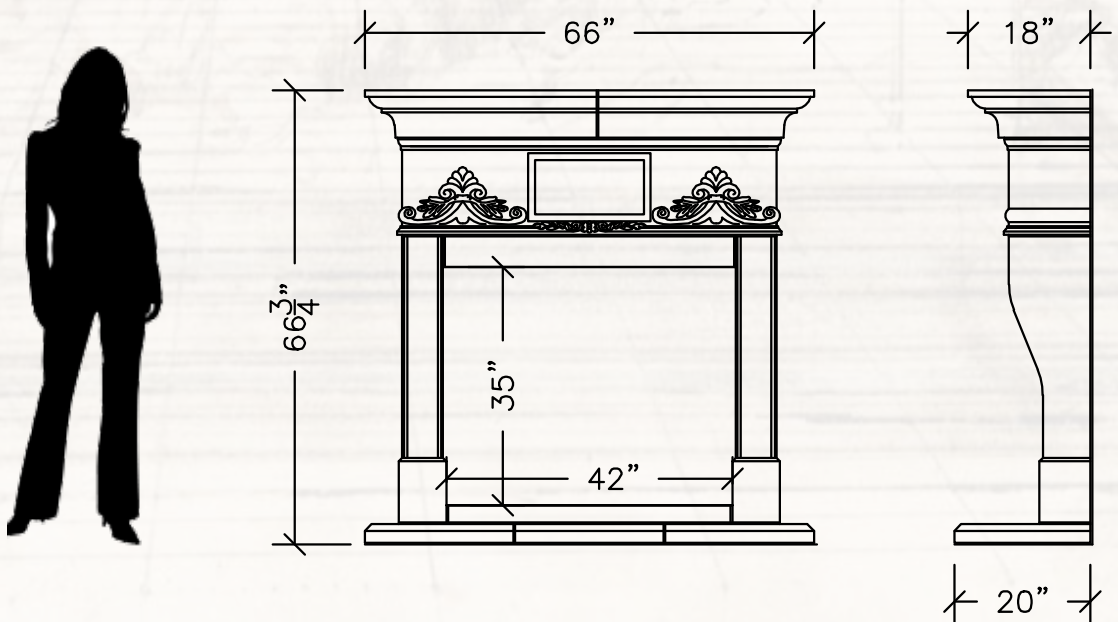

BELLA GAMBÀ





The Bella Gamba

"Beautiful legs" and fine attention to detail, this robust design makes perfect sense in each and every detail along it's sturdy double mantels to it's corbeled leg tops.

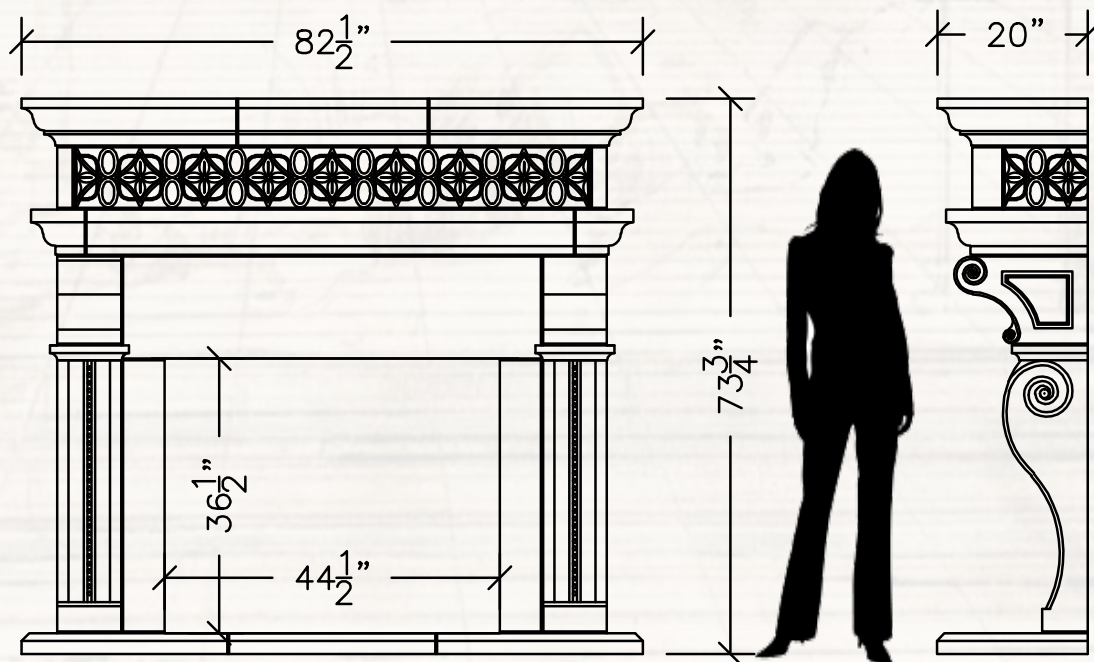

FIRENZE





Firenze

“ Florence” the ornate legs inspired by the Florence Cathedral cool the room instantly with a historic yet subtle feel.

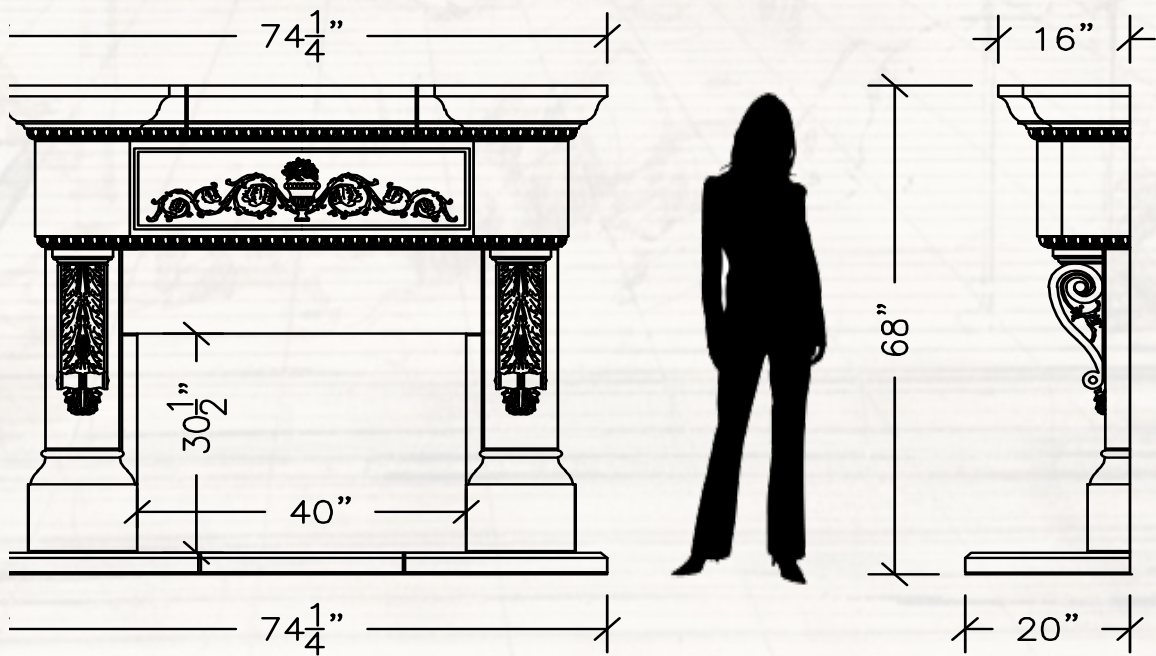

A C A N T U S





The Acantus

A beautiful ornate leaf leg with exceptional mantel accents, the Acantus can't help but impress.

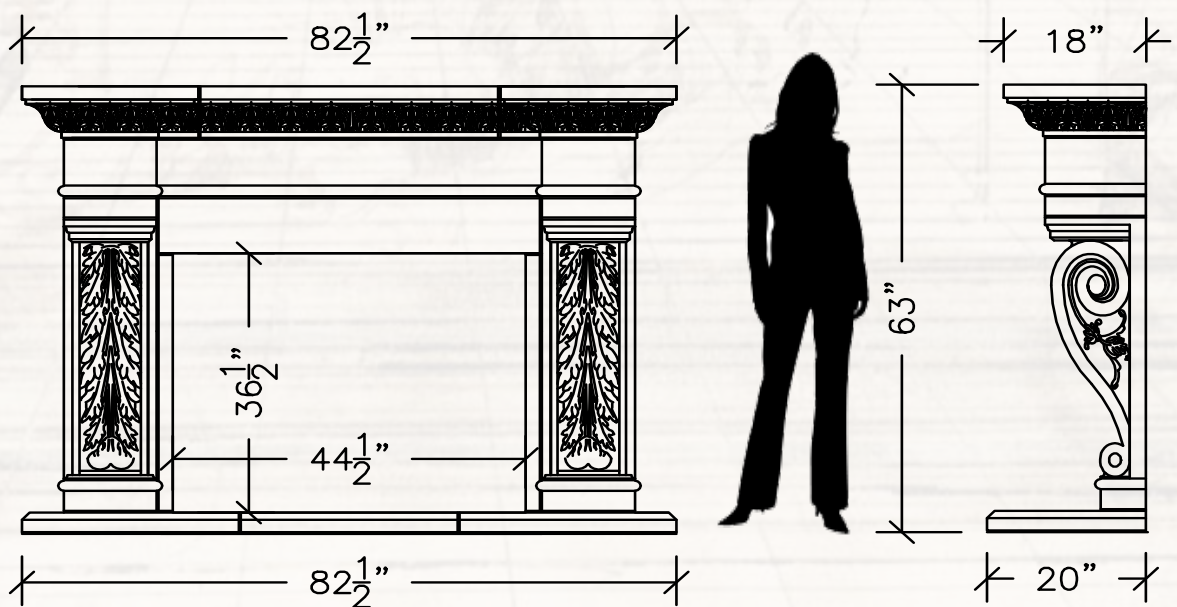

SATONE LUCIDO





Satone Lucido

Literally, "polished stone" these beautiful polished panels come together to create versatile shapes and lend itself to an industrial / contemporary decor. With or without the heavy duty bolt pattern this fireplace will get your attention.

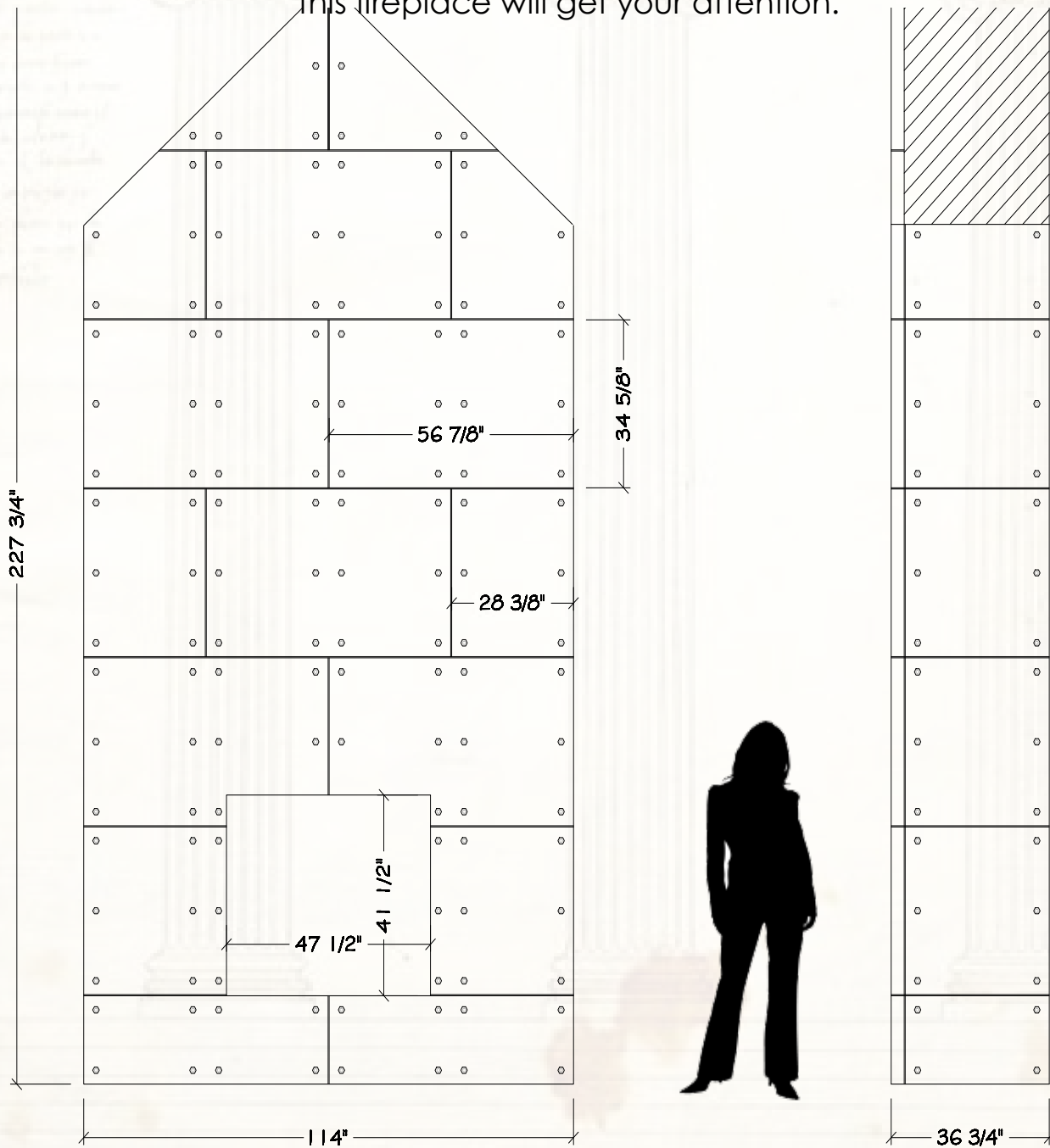

AGRA

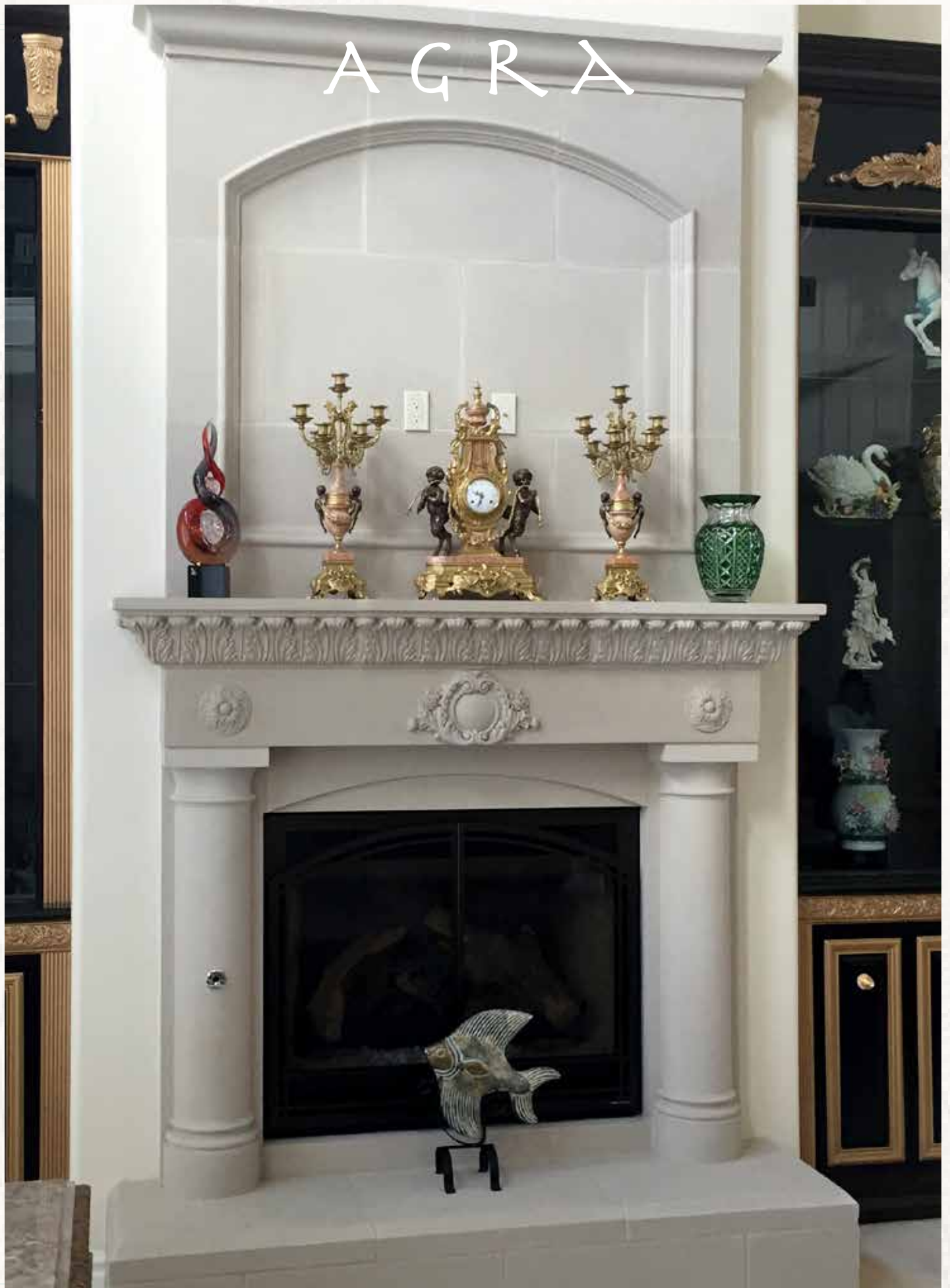



The Agra

The Agra combines ornate leaves with stately columns in fine fashion. Accent medallions finish this classic design.

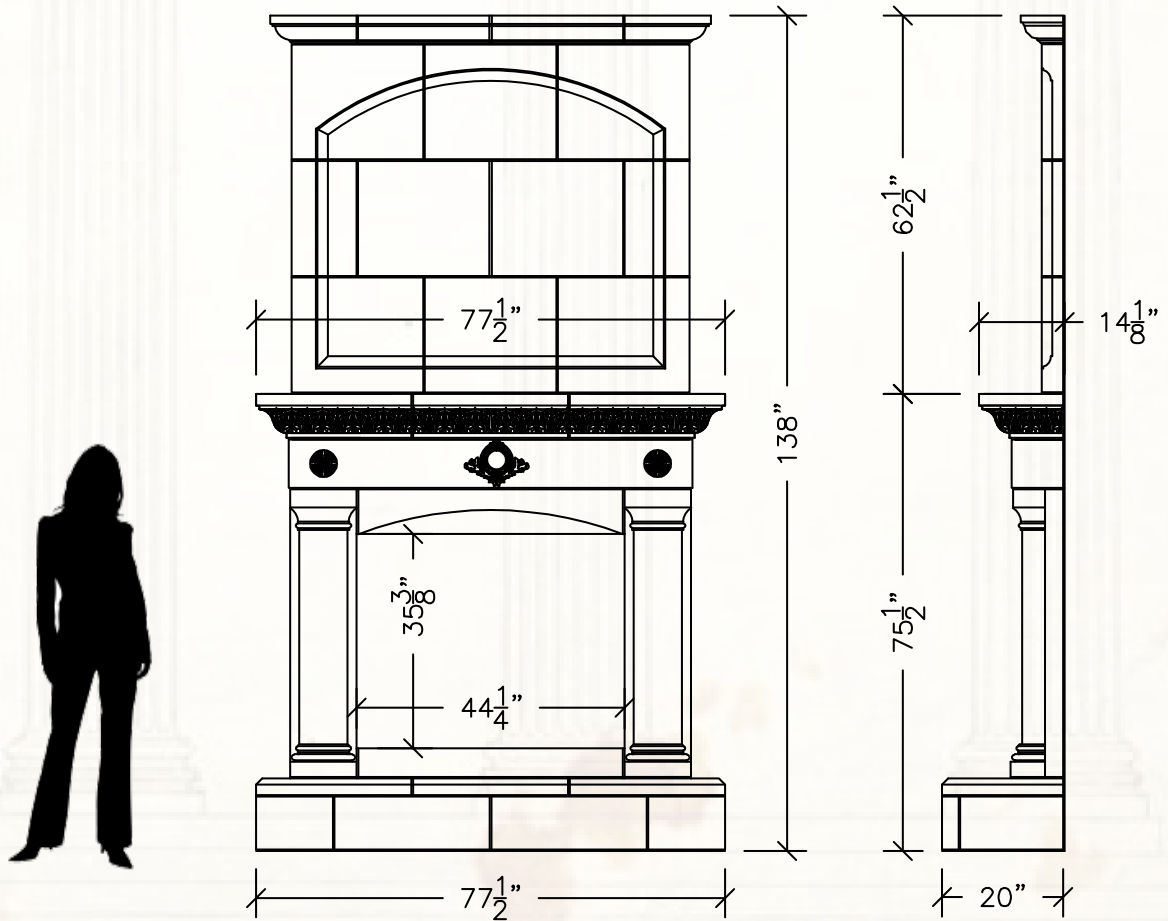

MARC ANTONY



The Marc Antony

Like it's namesake, This piece transforms your living space, demanding it's viewers to acquiesce to it's absolute and dominant presence.

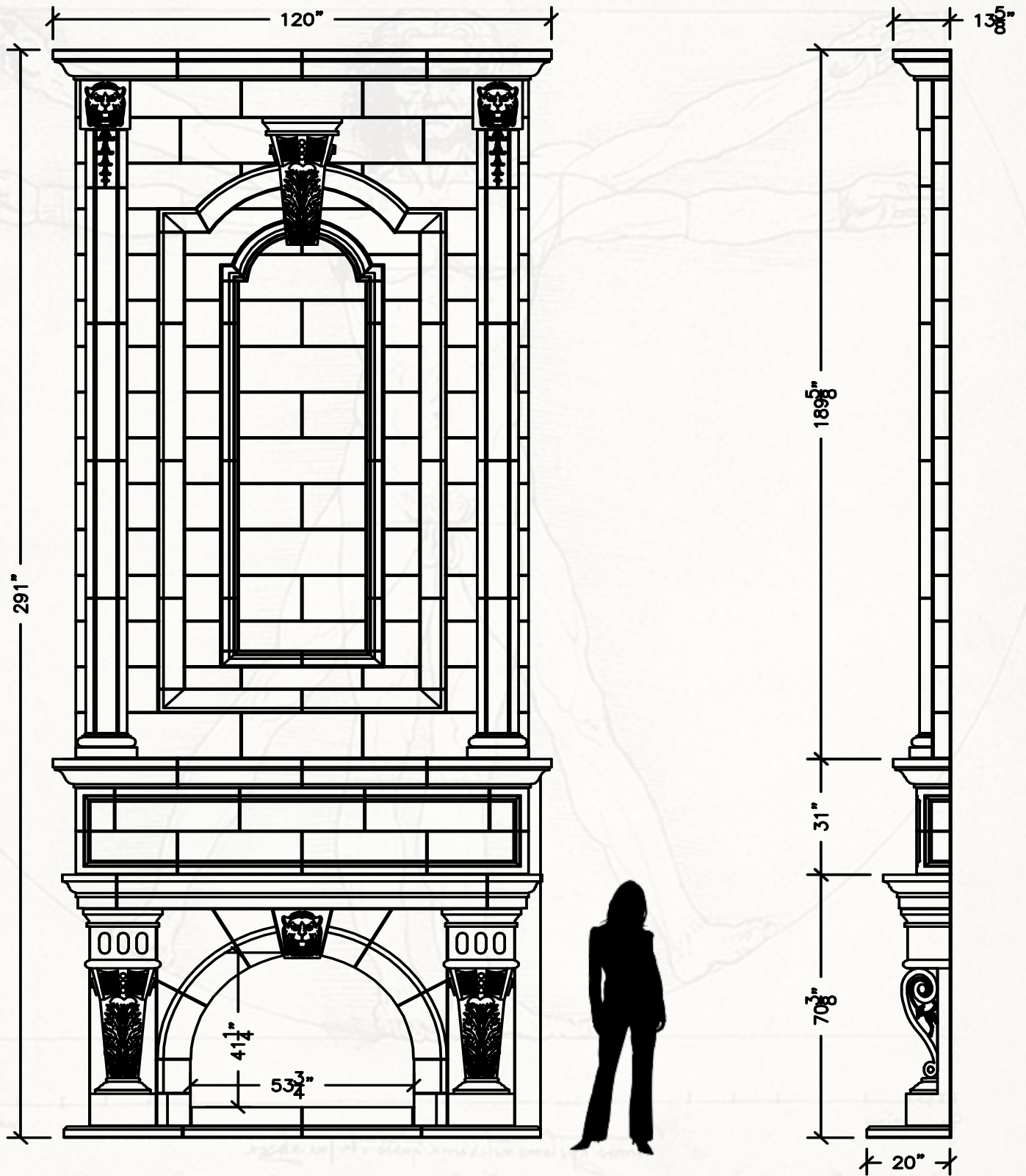

THE ATLAS





The Atlas

An easier job for Atlas to hold up this mantel than the universe.
This beautiful adaptation captivates the imagination while holding up it's omage to Greek architecture.

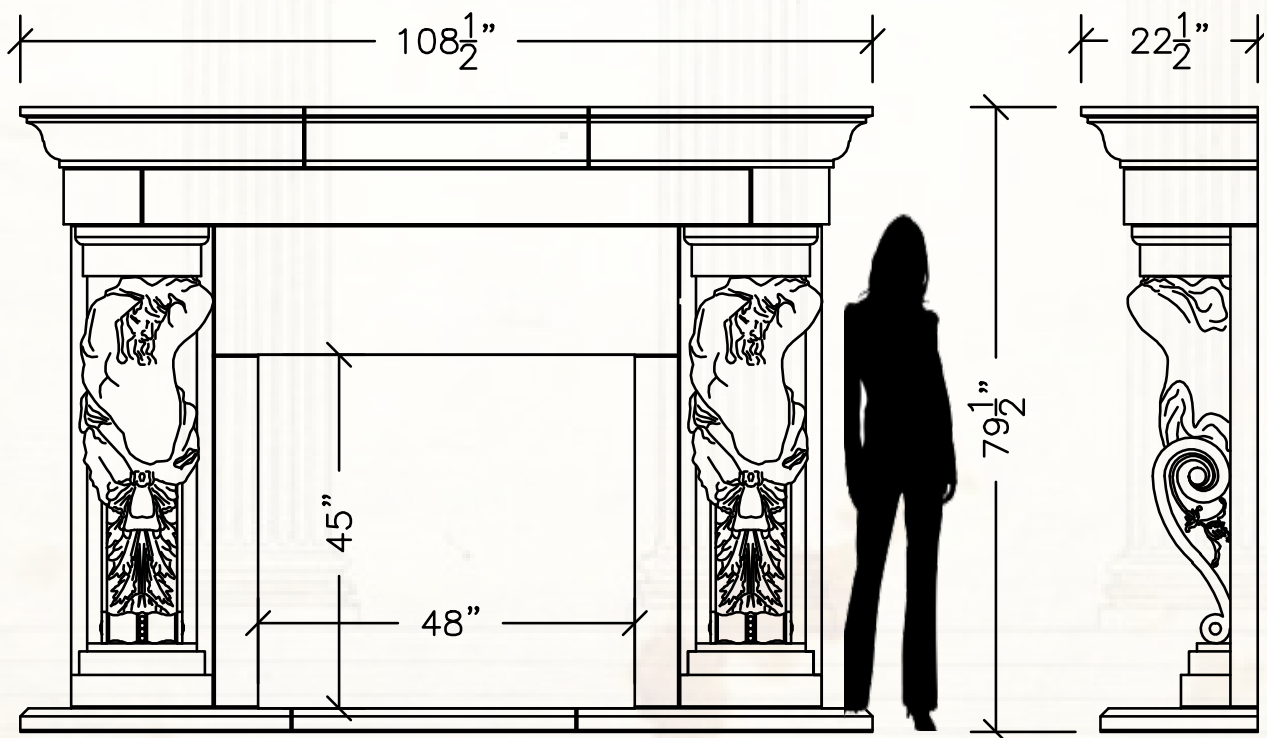

SEMPLICITÀ





Semplicità

“Simple Design” means smart, easy to understand, features. Thus the Semplicità is born. However to ignore it's charm is not so “simple”

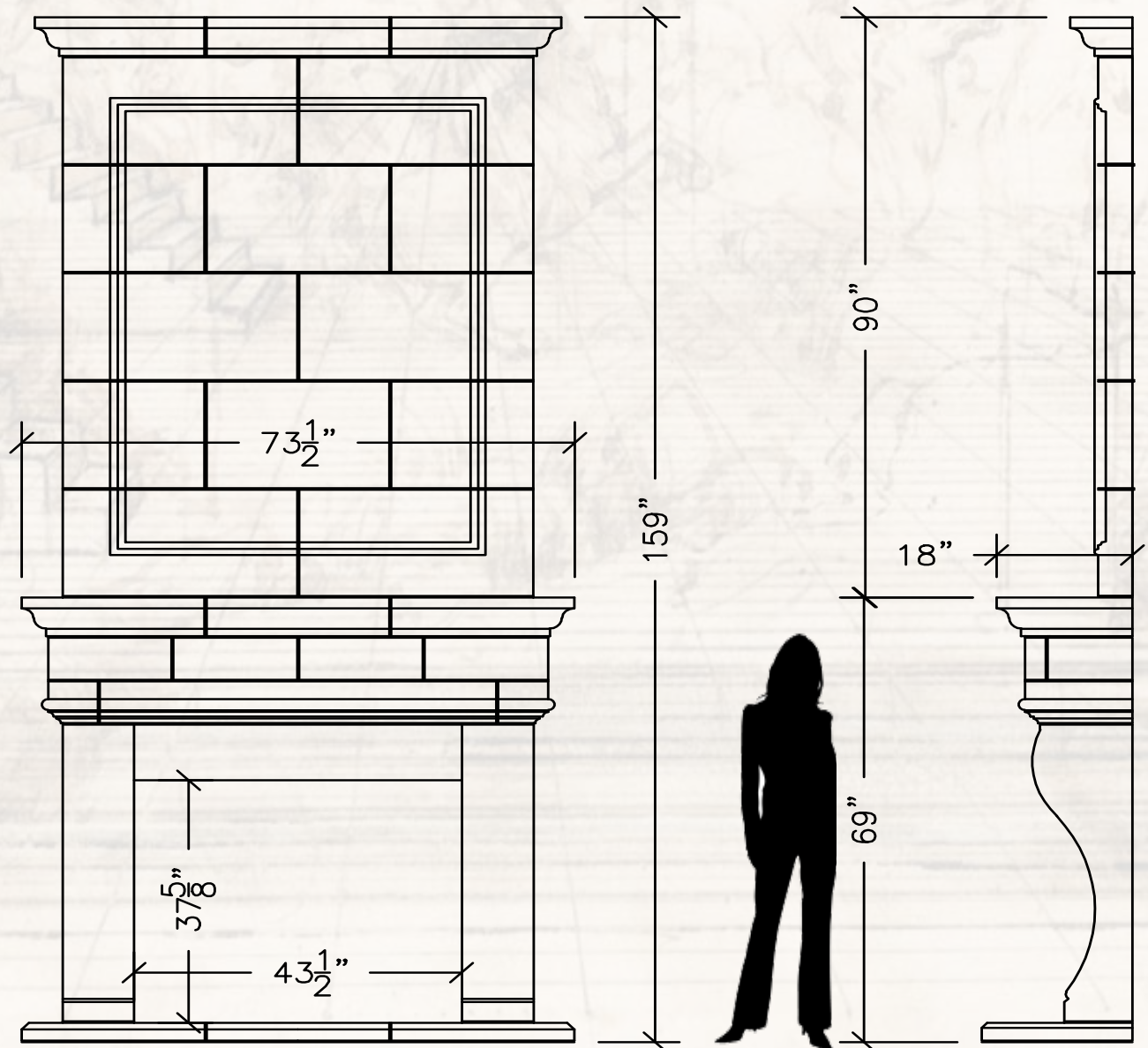



ELEGANTE



The Elegante

Featuring double mantels and eyebrow panels with neatly defined trim on the legs. Truly elegant.

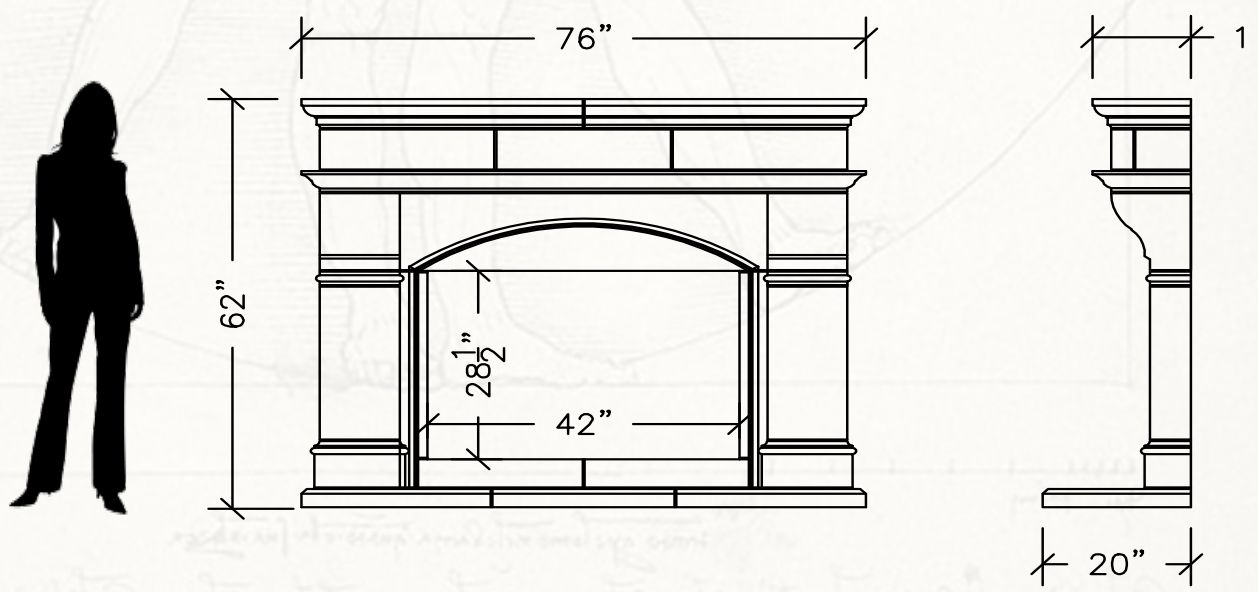

BELLA ORECCHIE





Bella Orecchie

"Pretty Ears" A regal sight to behold. This mantel seems to be listening in to the chorus of applause and awe from your guests.

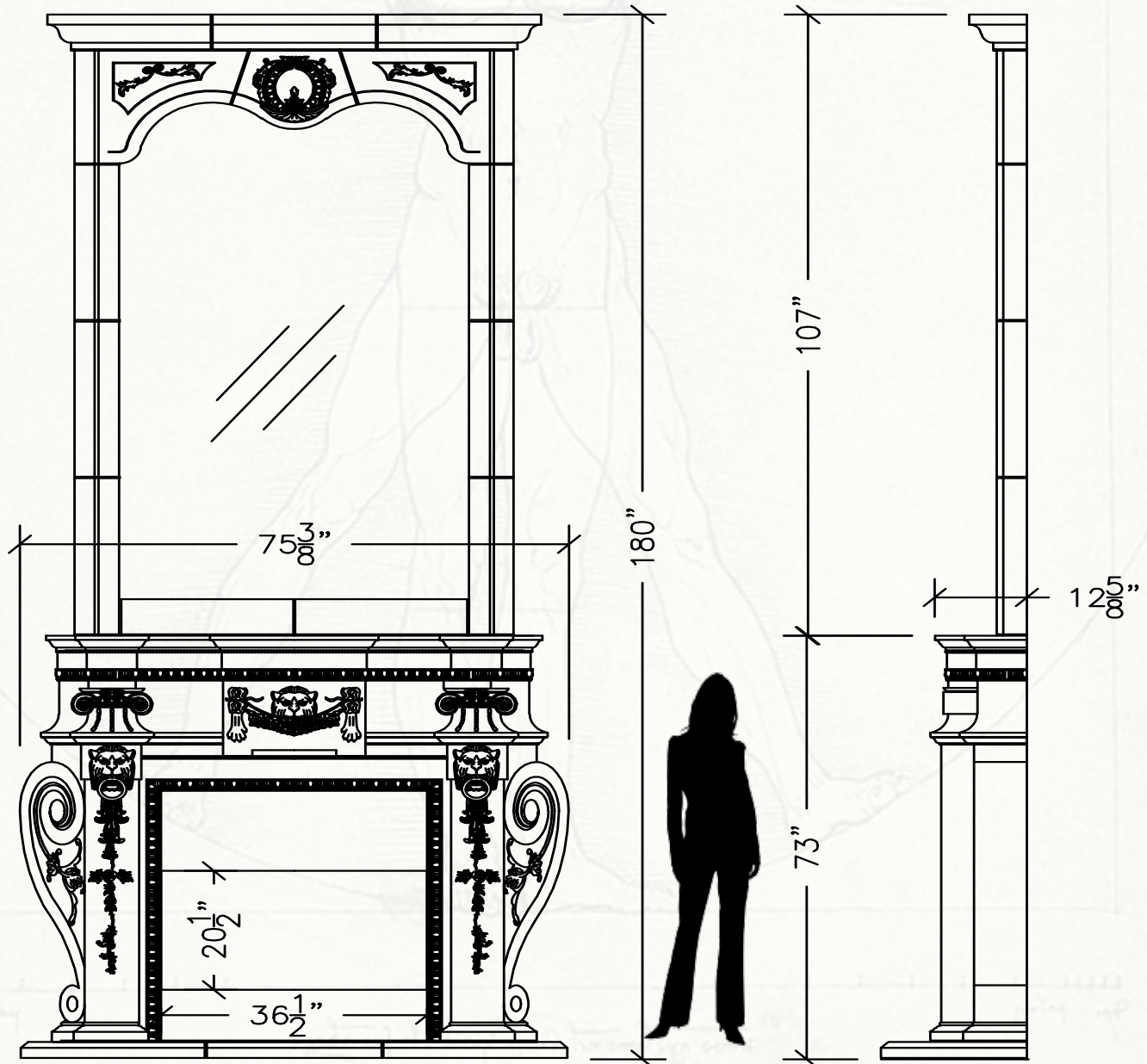

ARCO DE HERRADURA





Arco De Herradura

The "Horseshoe Arch" of Arabic decent gives the spice of the ancient culture's sophistication, married with the archetypal columns of ancient Rome and Greece. "Doves of Peace" soar the corners.

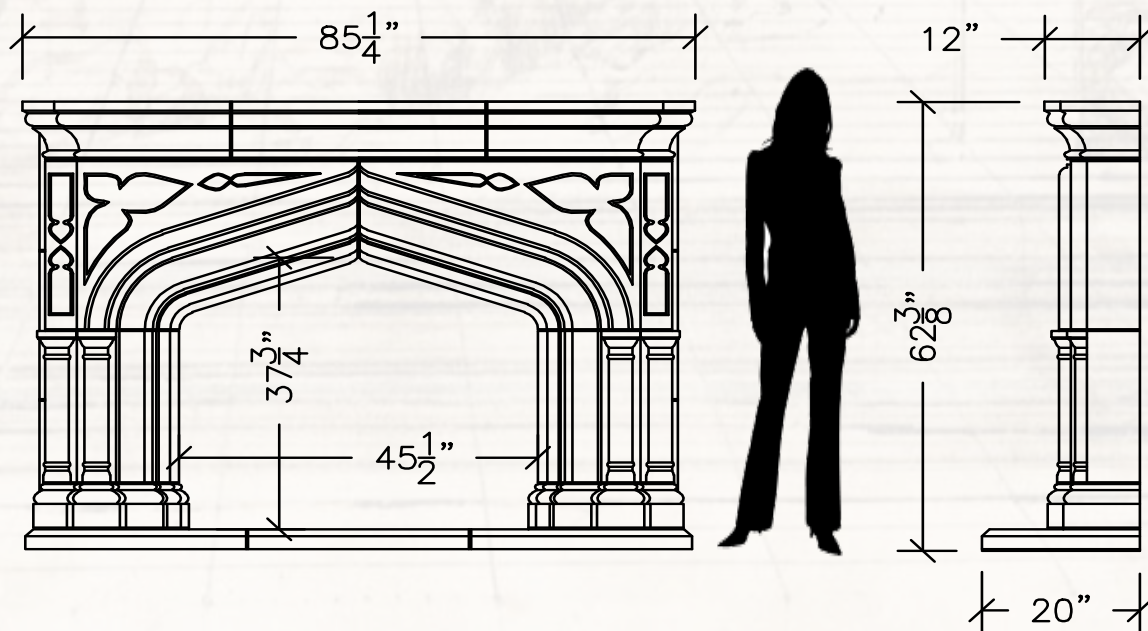

KITCHEN



It is rare to find an item you can add to today's modern kitchen. A kitchen hood is one of those items. In the pages that

N H O O D S



hen that can inspire “awe”, but a Renaissance cast stone
at follow, see if something we have inspires you.

FILIGRANA





The Filigrana

Made exclusively from plaster, this mantel borrows its name from the filigree design styles adapted by the French from early Egyptian designs. Lighter than stone, and provided in white plaster, the Filigrana can be colored to suite any decor!

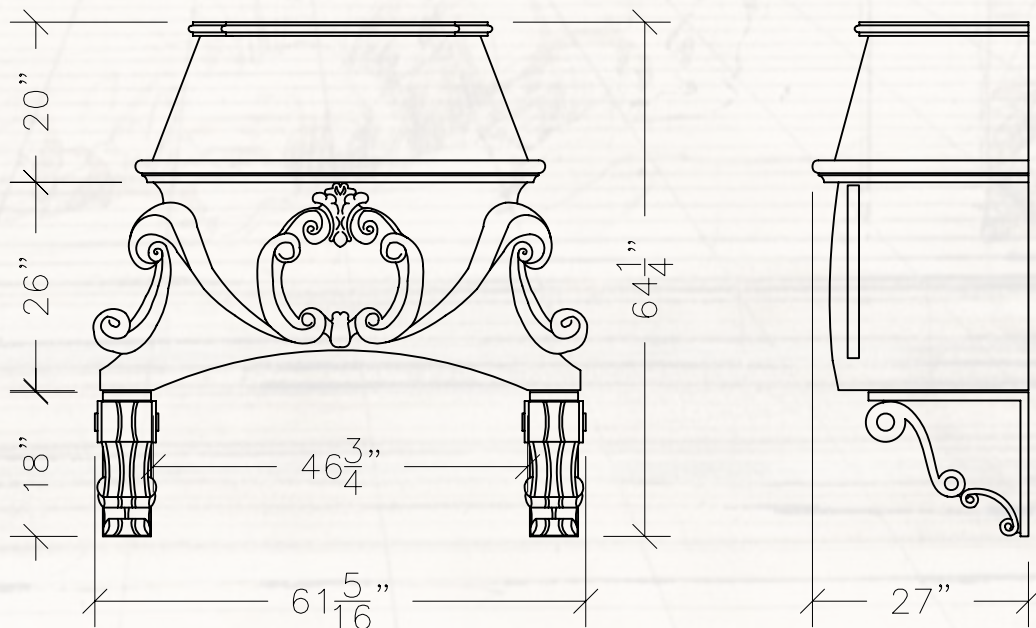

COMPAGNI





The Compagni

A stone mantel that is a "friend" to other upper stylings. In this picture, the upper section was tiled, but could also be a host of other textures.

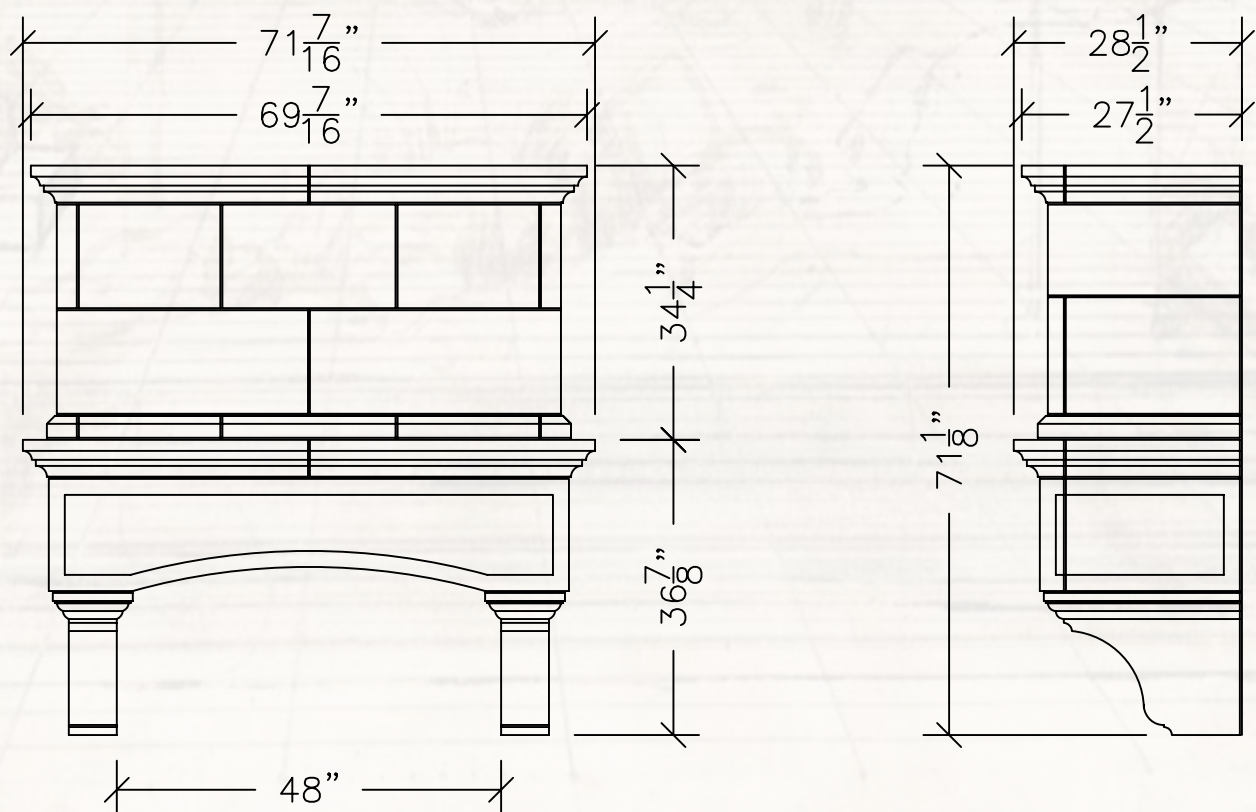

BELLA CUCINA

OLDE WORLD FINISH



HERE W COPPER

Bella Cucina

"Beautiful Kitchen", The Bella Cucina certainly does it's part to add warmth and charm! An alarming piece that draws you in and asks, "what's for dinner?"

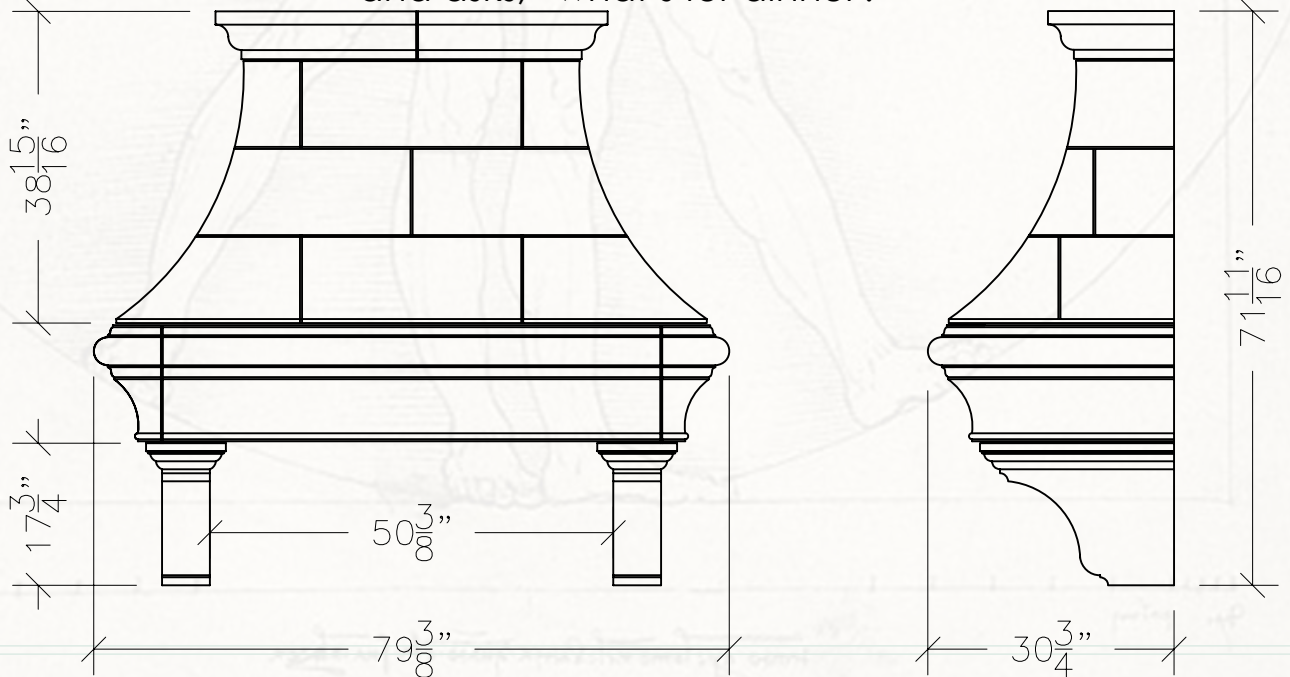

BELLA COMPANA



PLASTER AND WOOD

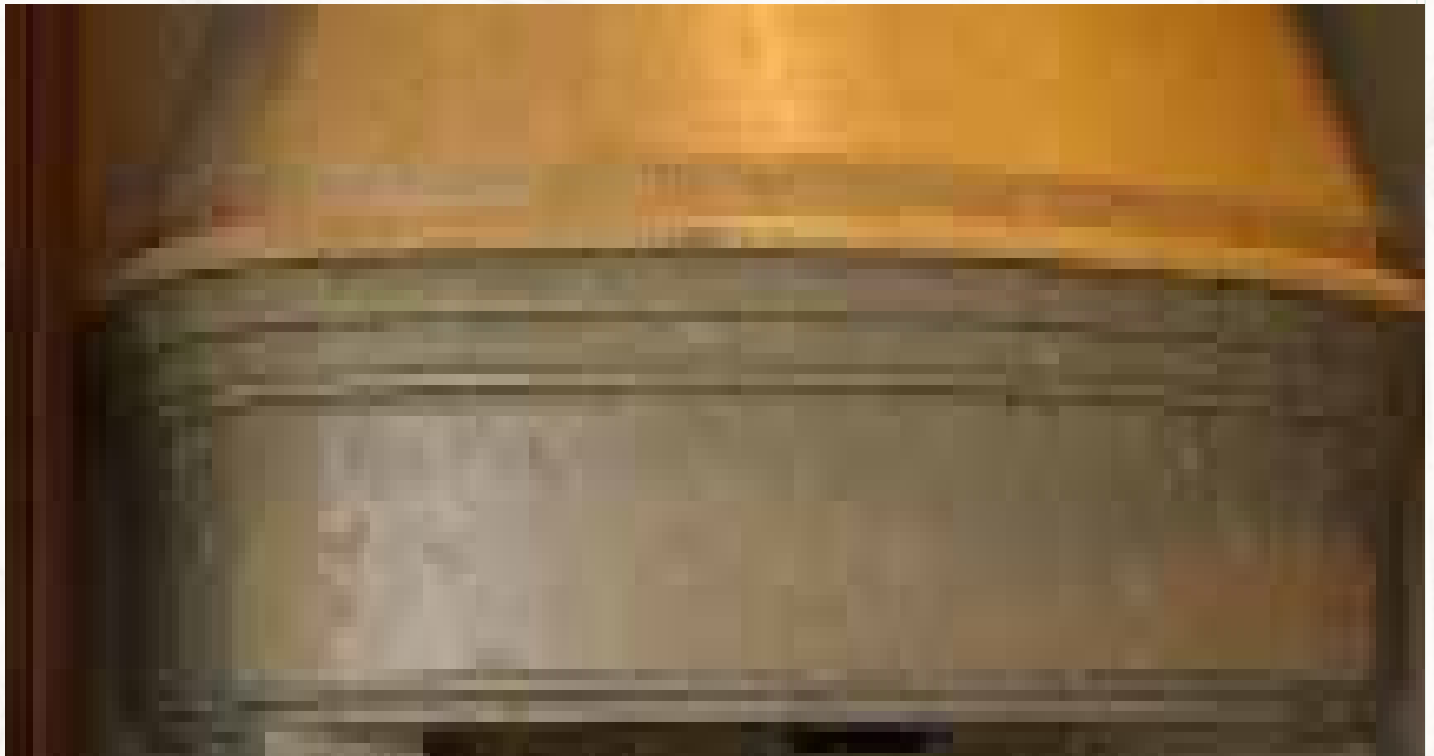

Bella Compana

“Beautiful Bell” Bella Compana a plaster kitchen hood, is open to different accent pieces. This flexible hood can use wood or plaster trim to accent the bell and the top.

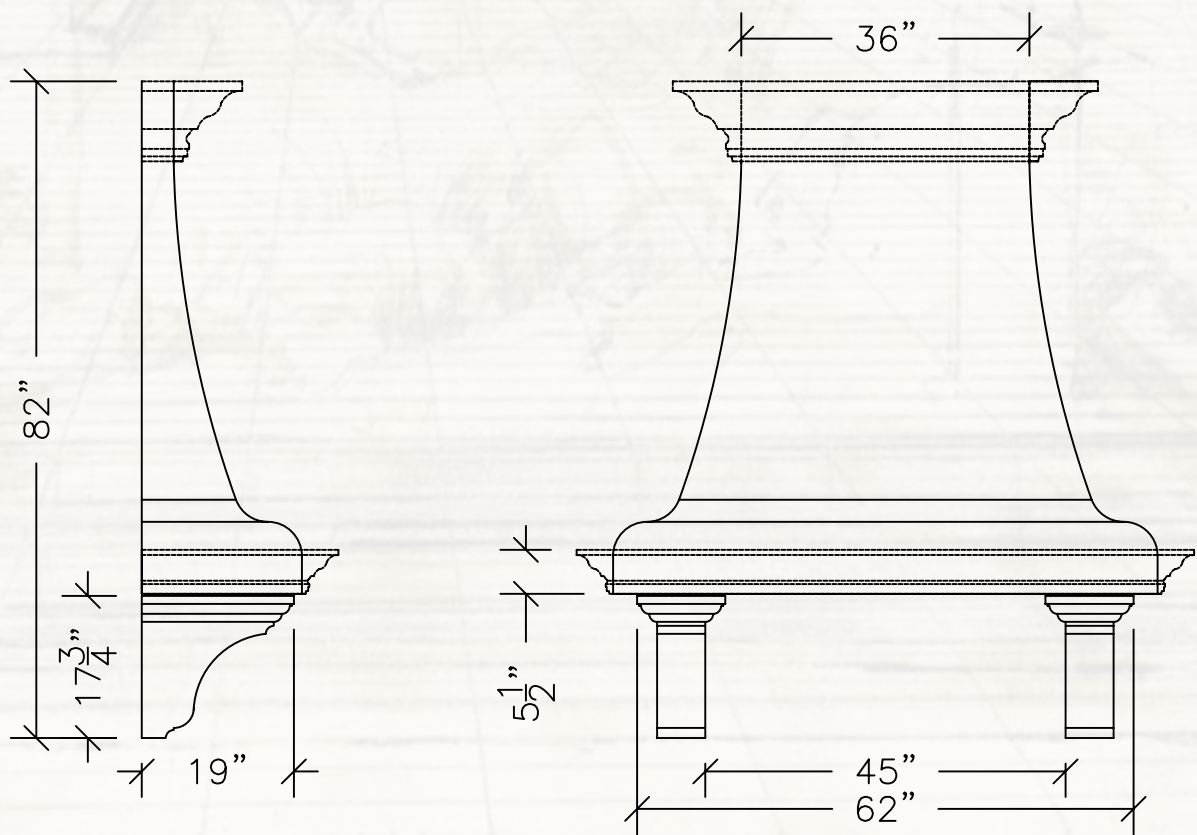

D A M E





The Dame

Meant for knighthood, this curvy, statuesque mantel borrows form from the prestigious name afforded women equal to knights.

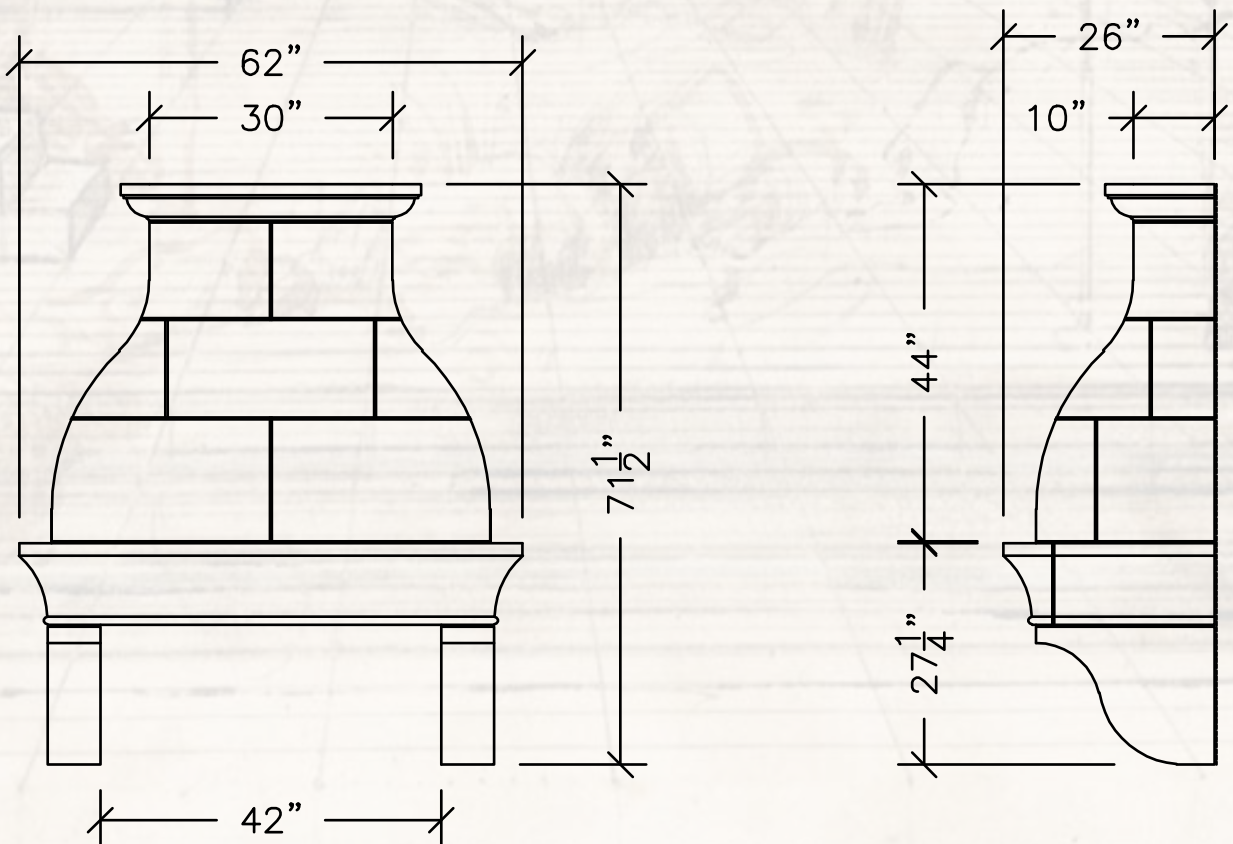

FLIRTARE





The Flirtare

A true "tease" in the kitchen. Fancy, but not too, Sturdy but delicate. With a little sophisticated whimsy to finish.

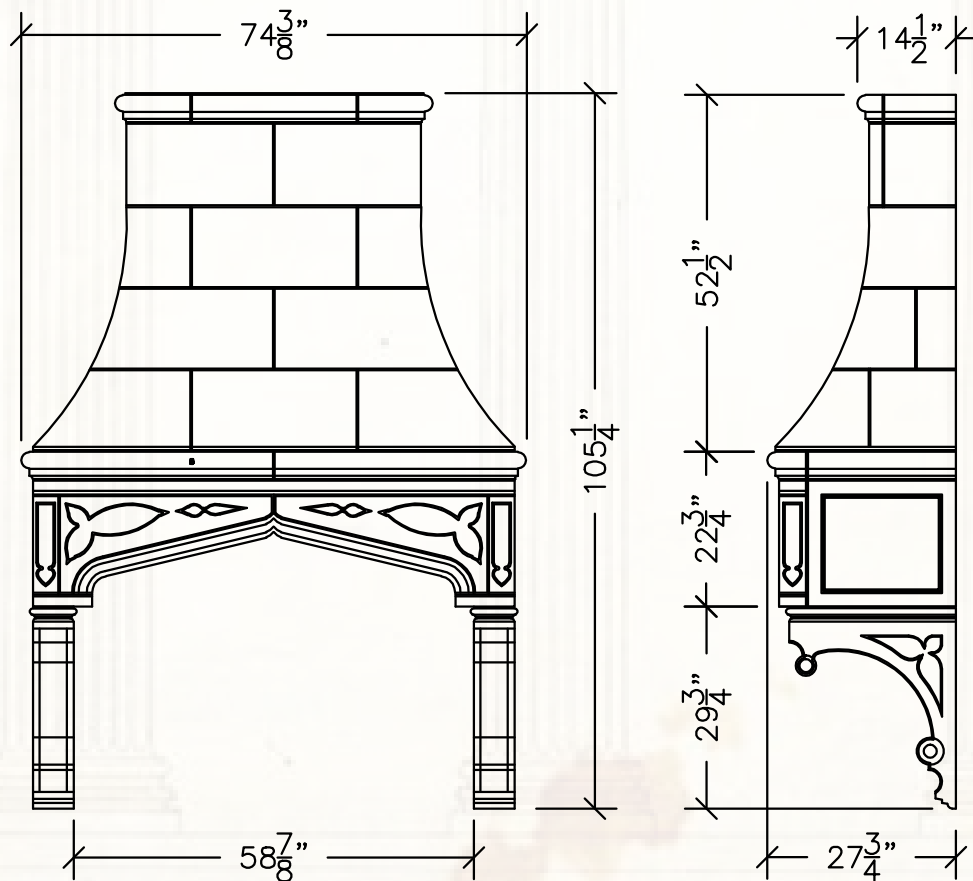

DAMASCUS





The Damascus

Drawing from its ancient city's namesake, The Damascus takes its shape and textures from one of the oldest continually inhabited cities in the world.

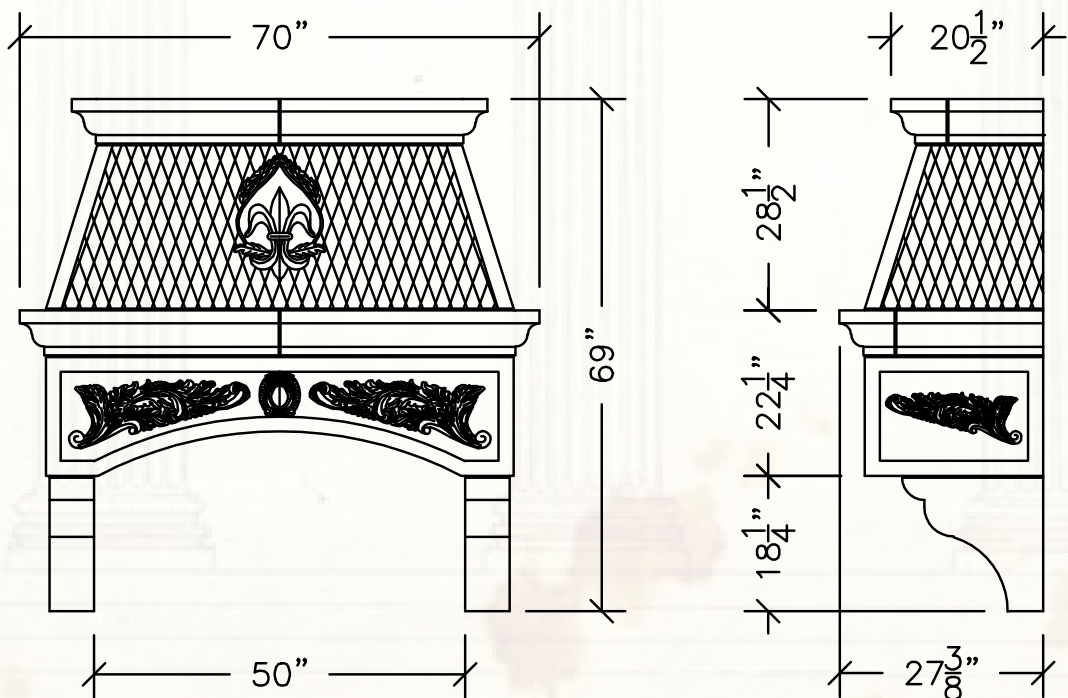

UPPER MANTEL SELECTIONS

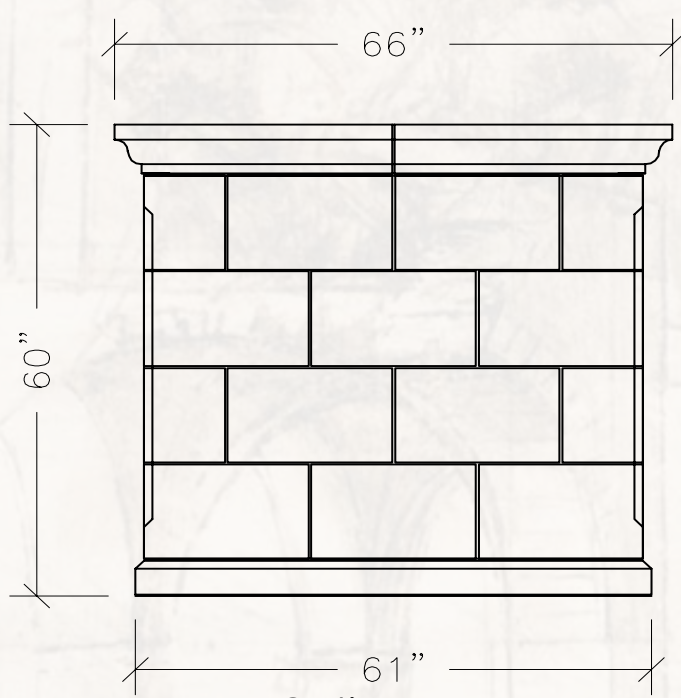

Option I
Stately Mantel

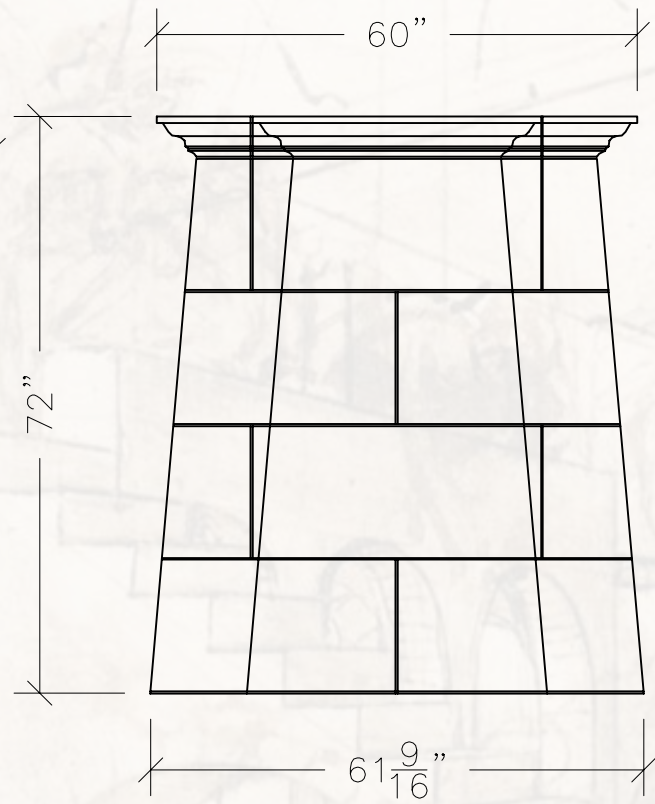

Option II
Double Taper

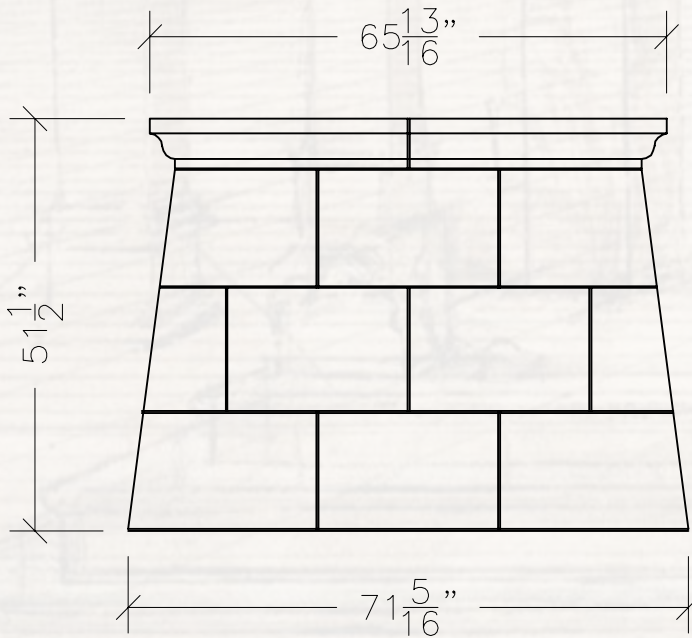

Option III
Single Taper

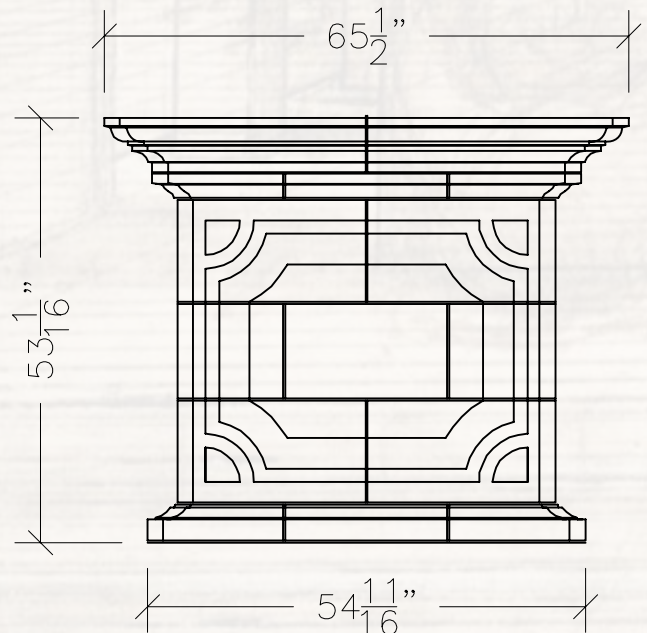

Option IV
Fancy Chamfer

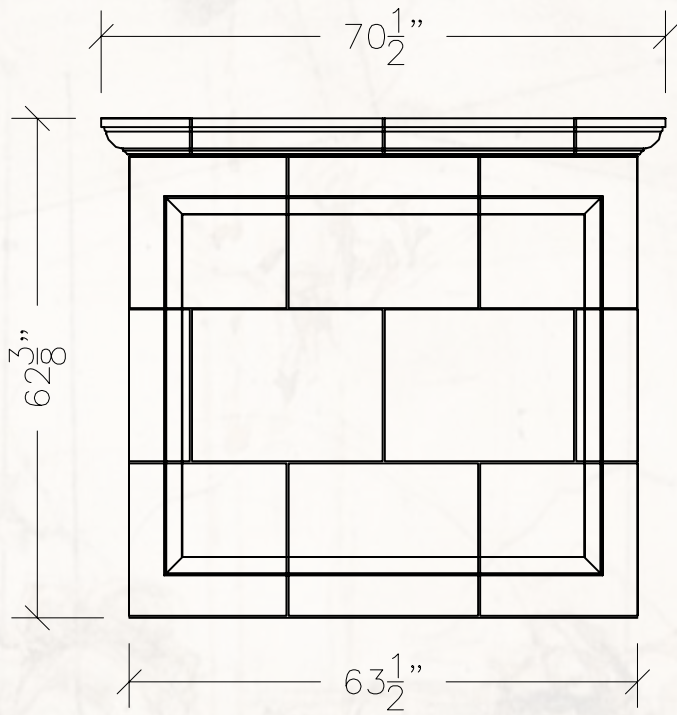

Option V
Chamfer

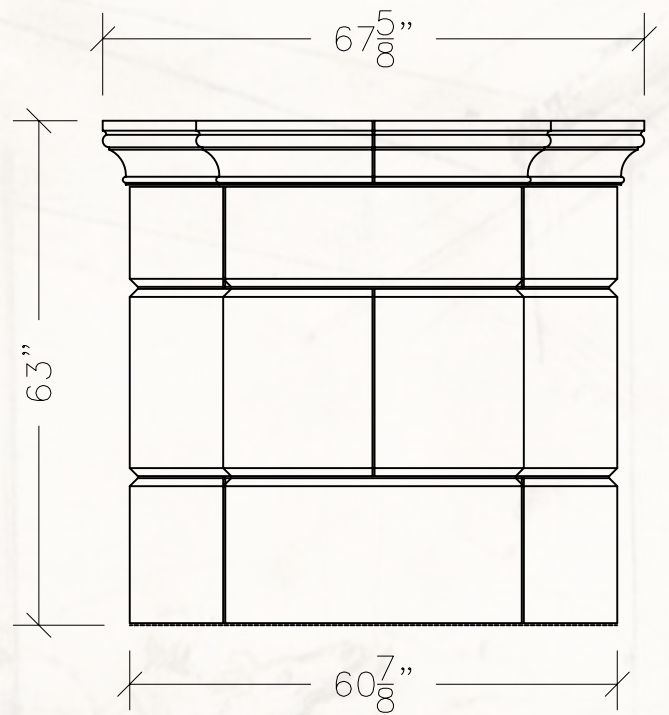

Option VI
Raised Static

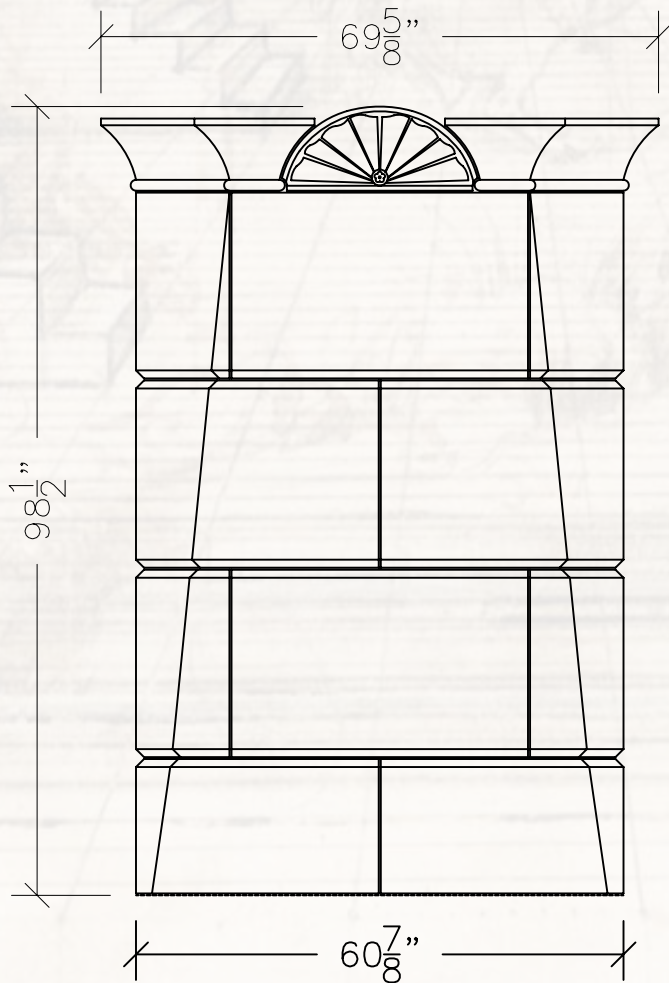

Option VII
Taper Static w Medallion

HEARTH OPTIONS

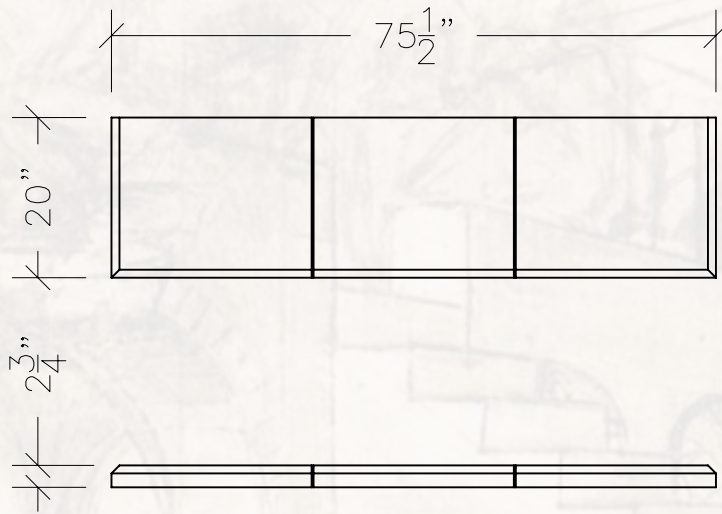

STANDARD HEARTH

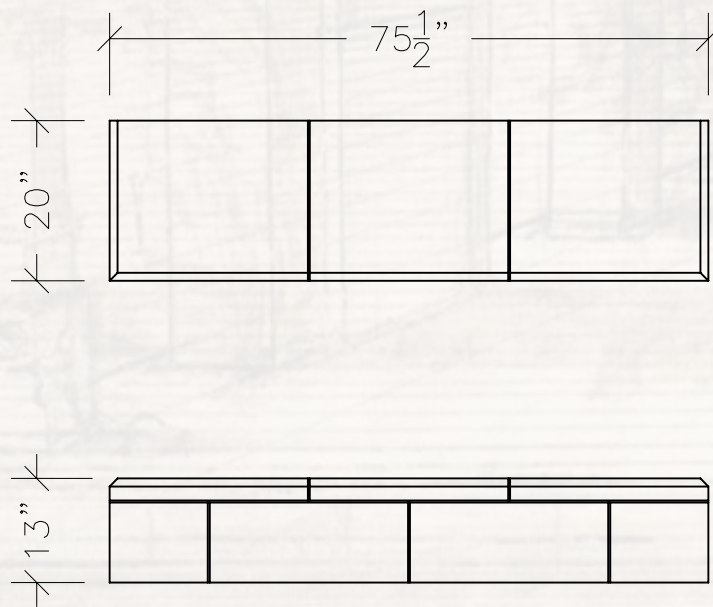

STANDARD RAISED HEARTH

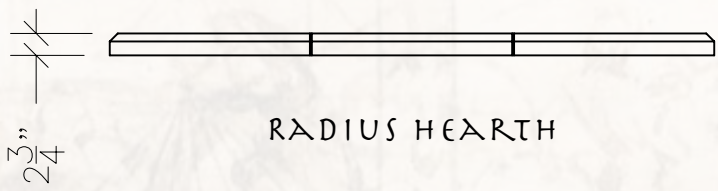
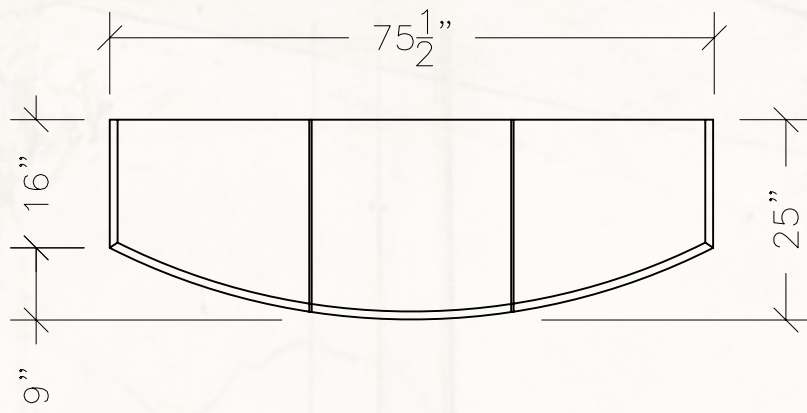

RADIUS HEARTH

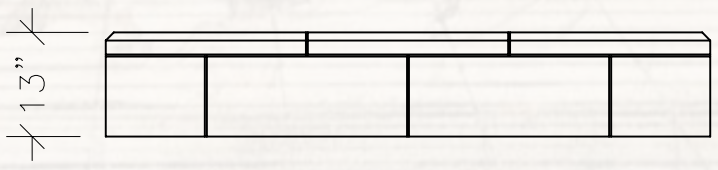
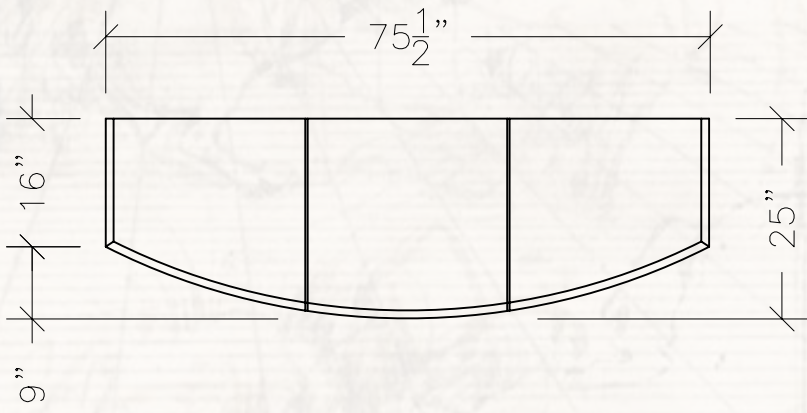

RADIUS RAISED HEARTH

